

---

# MANUAL TRANSMISSION F5MR1, F5MR2, F5MR3

## CONTENTS

GENERAL INFORMATION .....	22A-0-3
1. SPECIFICATIONS .....	22A-1-1
GENERAL SPECIFICATIONS .....	22A-1-1
TORQUE SPECIFICATIONS .....	22A-1-1
LUBRICANTS .....	22A-1-2
SEALANTS AND ADHESIVES .....	22A-1-2
2. SPECIAL TOOLS .....	22A-2-1
3. TRANSMISSION .....	22A-3-1
4. OUTPUT SHAFT .....	22A-4-1
5. DIFFERENTIAL .....	22A-5-1
6. CLUTCH HOUSING .....	22A-6-1
7. CONTROL LEVER .....	22A-7-1
8. INPUT SHAFT .....	22A-8-1

**NOTES**

## GENERAL INFORMATION

### F5MR1, F5MR2 – Five-speed front wheel drive transmission

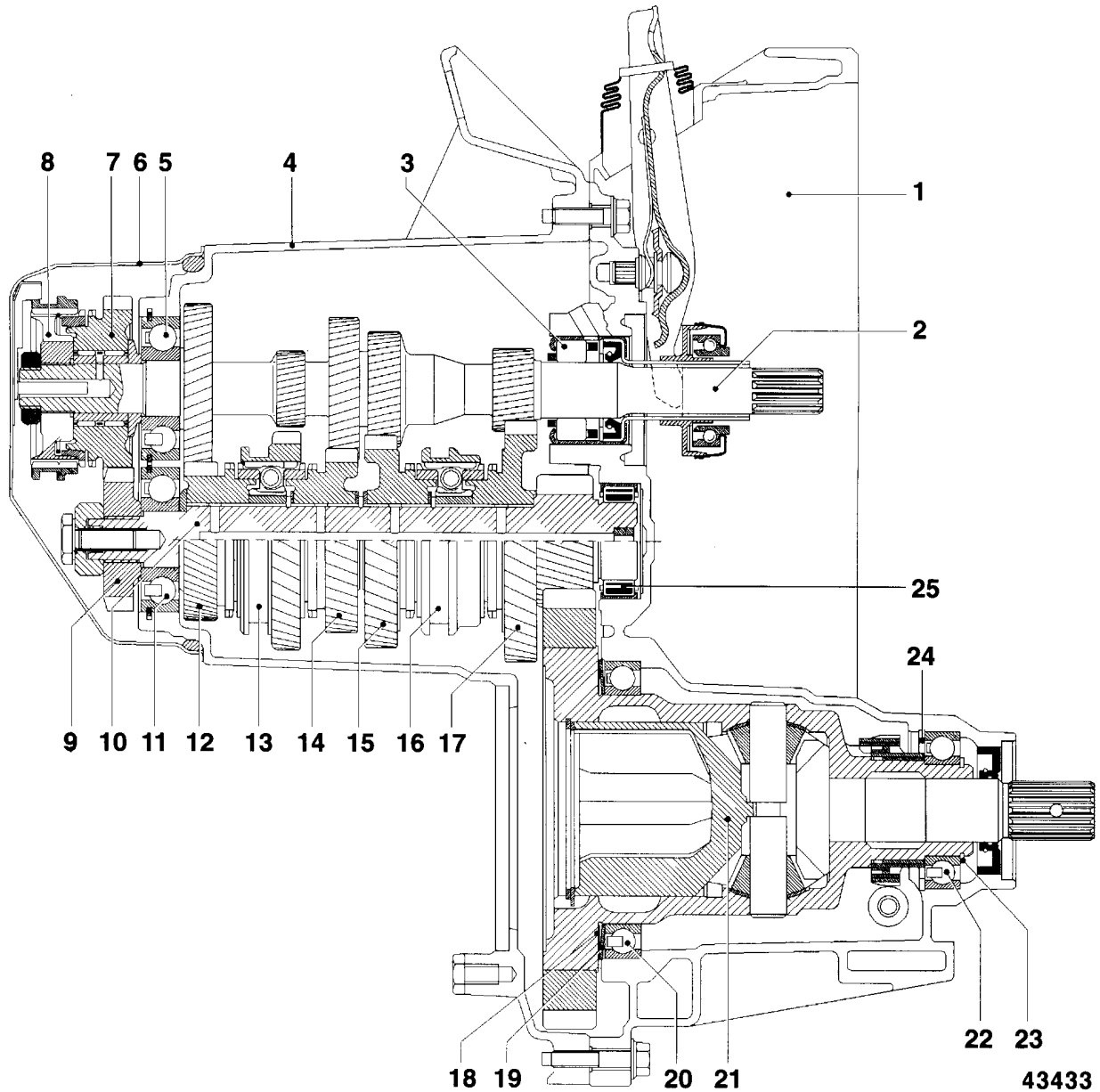

- |   |   |
|---|---|
| 1. Clutch housing                         | 14. 3rd speed gear                        |
| 2. Input shaft                            | 15. 2nd speed gear                        |
| 3. Input shaft bearing                    | 16. 1st – 2nd speed synchronizer assembly |
| 4. Transmission case                      | 17. 1st speed gear                        |
| 5. Input shaft bearing                    | 18. Guard ring                            |
| 6. Rear cover                             | 19. Spring ring                           |
| 7. 5th speed gear                         | 20. Differential bearing                  |
| 8. 5th speed synchronizer assembly        | 21. Differential                          |
| 9. 5th gear wheel                         | 22. Differential bearing                  |
| 10. Output shaft                          | 23. Snap ring                             |
| 11. Output shaft bearing                  | 24. Snap ring                             |
| 12. 4th speed gear                        | 25. Output shaft bearing                  |
| 13. 3rd – 4th speed synchronizer assembly |   |

F5MR3 – Five-speed front wheel drive transmission

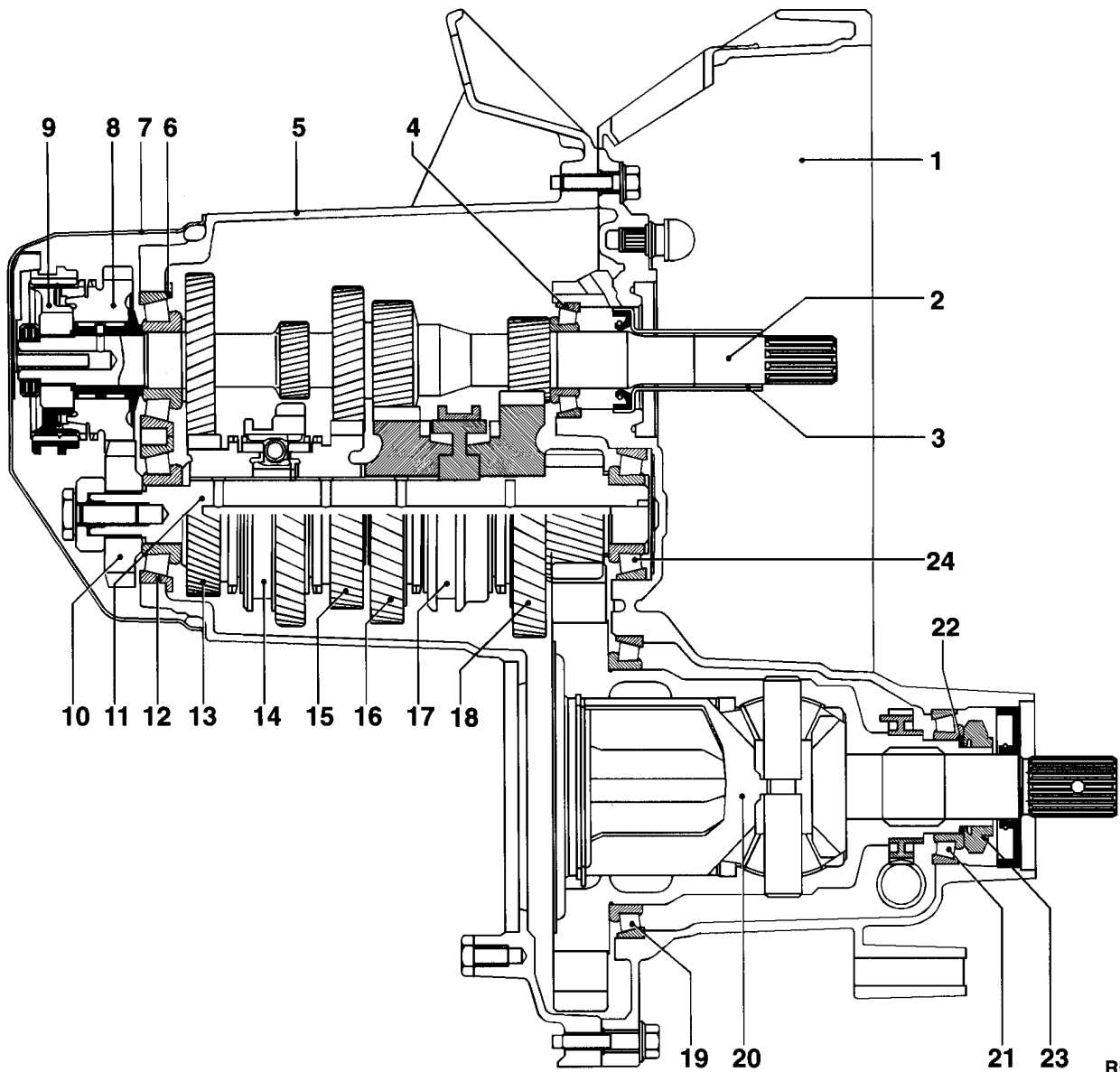

- |                                    |   |
|------------------------------------|---|
| 1. Clutch housing                  | 14. 3rd – 4th speed synchronizer assembly |
| 2. Input shaft                     | 15. 3rd speed gear                        |
| 3. Guide bushing                   | 16. 2nd speed gear                        |
| 4. Input shaft bearing             | 17. 1st – 2nd speed synchronizer assembly |
| 5. Transmission case               | 18. 1st speed gear                        |
| 6. Input shaft bearing             | 19. Differential bearing                  |
| 7. Rear cover                      | 20. Differential                          |
| 8. 5th speed gear                  | 21. Differential bearing                  |
| 9. 5th speed synchronizer assembly | 22. Shim                                  |
| 10. 5th gear wheel                 | 23. Lock nut                              |
| 11. Output shaft                   | 24. Output shaft bearing                  |
| 12. Output shaft bearing           |   |
| 13. 4th speed gear                 |   |

RMT0001

# 1. SPECIFICATIONS

## GENERAL SPECIFICATIONS

Items		Specifications		
Model		F5MR1 <For CARIS-MA>, F5MR2	F5MR1 <For SPACE STAR>	F5MR3
Type		Manual, 5-speed, front wheel drive	Manual, 5-speed, front wheel drive	Manual, 5-speed, front wheel drive
Gear ratio	1st	3.363	3.727	3.727
	2nd	2.047	2.047	2.047
	3rd	1.321	1.321	1.321
	4th	0.966	0.966	0.971
	5th	0.794	0.794	0.756
	Reverse	3.545	3.545	3.545
Final reduction ratio		4.066	4.214	3.437

## TORQUE SPECIFICATIONS





Items	Specifications (Nm)
Bearing housing bolts	25
Input shaft lock nut	135
Output shaft bolt	80
Cover bolts	25
Locating pin	24
Back-up lamp switch	22
Drain plug	22
Filler/level plug	2.25
Sealing plugs	25
Guide bushing bolts <F5MR3>	25
Differential nut <F5MR3>	130

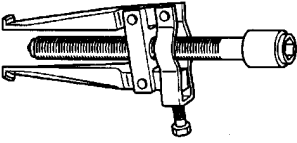
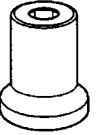
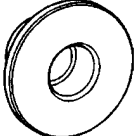

**LUBRICANTS**

Items	Quantity	Specified lubricant
Transmission oil	3.4 ℓ	Elf Tranself TRX 75W – 80W (XT3556)
Rear cover O-ring	As required	Elf Tranself TRX 75W – 80W (XT3556)
All internal parts	As required	Elf Tranself TRX 75W – 80W (XT3556)
Shift lever	As required	Lithium MoS2
Shift lever bearing bush	As required	Lithium MoS2
Selector shaft oil seal	As required	Lithium MoS2
Speedometer driven gear	As required	Multi-purpose grease
Differential side gear	As required	Multi-purpose grease
Differential pinion gear	As required	Multi-purpose grease
Differential pinion washer	As required	Multi-purpose grease
Differential side oil seal	As required	Multi-purpose grease

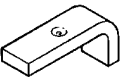
**SEALANTS AND ADHESIVES**

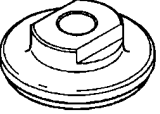
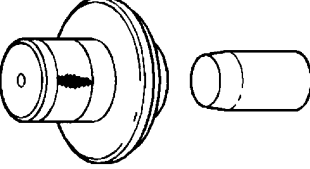
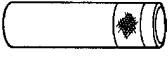
Items	Specified sealants and adhesives
5th gear wheel on output shaft	Loctite 242
5th gear wheel bolt	Loctite 242
Plastic cover on release fork ball and socket joint	Loctite 415
Transmission case mating surface	Loctite 518
Locating pin for 5th gear	Loctite 572
Back-up lamp switch	Loctite 572
Differential nut <F5MR3>	Loctite 270

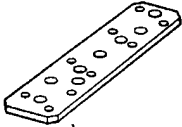
Tool	Number	Name	Use
	MB996001	Bearing puller	Removing output shaft front bearing
	MB996003	Socket wrench	Removing and installing differential gear <F5MR3>
	MB996004	Bearing drift	Fitting large and small bearing cups <F5MR3>
	MB996005	Counterhold	Removing and installing differential gear <F5MR3>
	MB996006	Bracket	Removing output shaft front bearing
	MB996007	Bearing bush drift	Fitting selector shaft bushes
	MB996008	Bearing drift	Fitting large and small bearing cups <F5MR3>
	MB996010	Oil seal drift	Fitting differential gear assembly oil seal
	MB996011	Bearing drift	Fitting input shaft bearing cup <F5MR3>

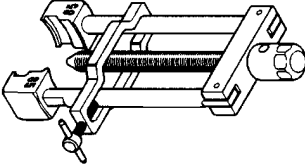
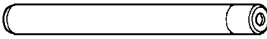
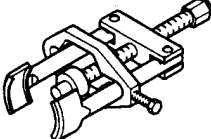
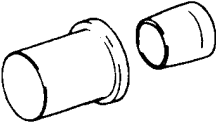
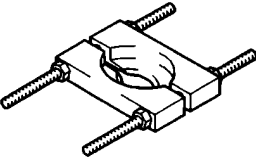
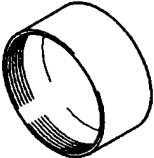
Tool	Number	Name	Use
	MB996012	Mounting plate	Calculate the pre-tention of input and output shafts with new bearings <F5MR3>
	MB996013	Bearing drift	Fitting output shaft bearing <F5MR3>
	MD998019	Spring pin extractor	Removing spring pins
	MD998020	Bearing puller	Removing 5th gear synchronizer hub
	MD998245	Spring pin installer	Installation of spring pin and lock pin
	MD998348	Bearing and gear puller	Removing 5th gear wheel
	MD998717	Installer	Fitting input shaft front bearing <F5MR1, F5MR2>
	MD998801	Bearing remover	Removing input and output shaft bearings <F5MR3>
	MD998812	Installer cap	Fitting 4th gear wheel bearing bush <F5MR3>

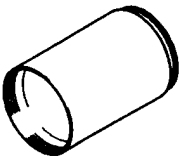
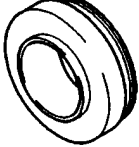

Tool	Number	Name	Use
	MD998813	Installer – 100	Fitting 4th gear wheel bearing bush <F5MR3>
	MD998819	Installer adapter (40)	Fitting 4th gear wheel bearing bush <F5MR3>

### 3. TRANSMISSION

#### DISASSEMBLY AND REASSEMBLY <F5MR1, F5MR2>

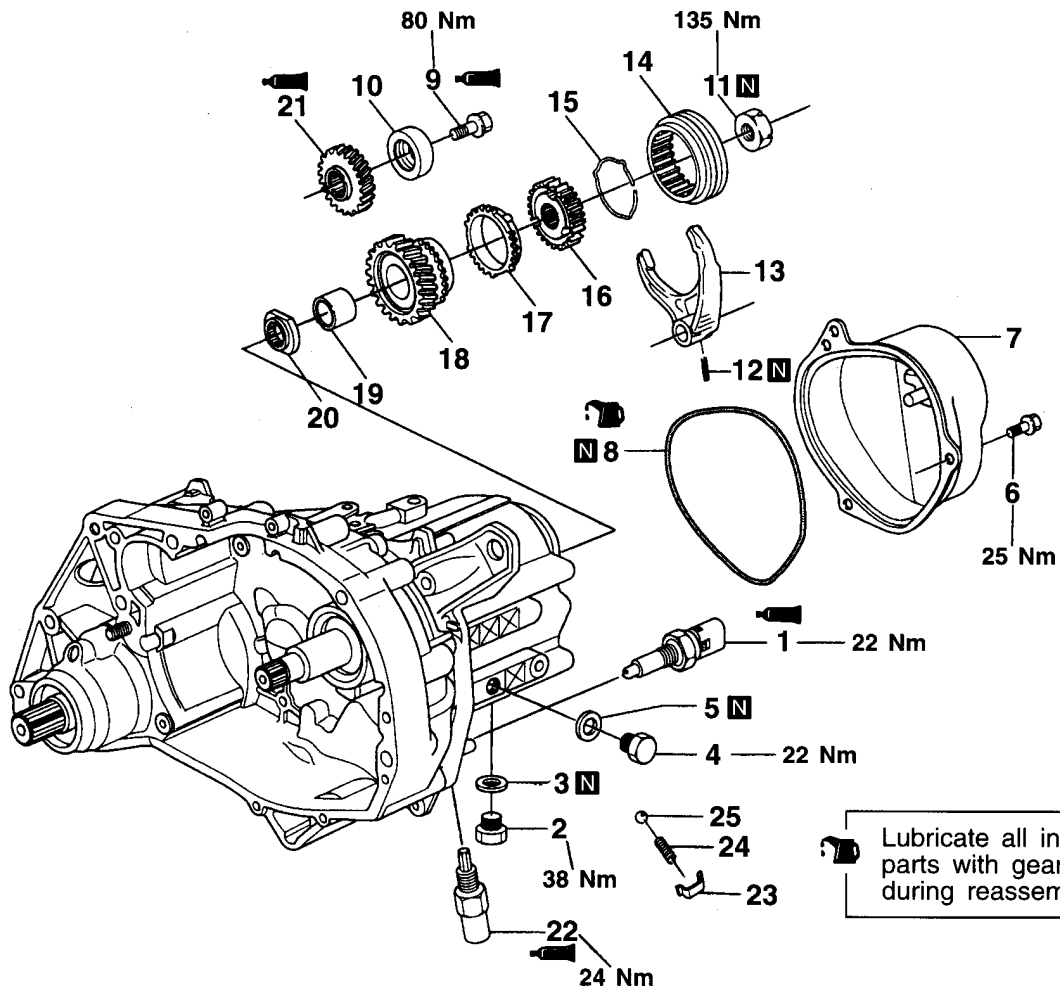

43434

#### Disassembly steps

- |     |                        |     |     |                         |
|-----|------------------------|-----|-----|-------------------------|
| ▶Z◀ | 1. Back-up lamp switch | ◀C▶ | ◀V▶ | 14. Synchronizer sleeve |
|     | 2. Drain plug          | ◀D▶ | ◀V▶ | 15. Synchronizer spring |
|     | 3. Gasket              | ◀D▶ | ◀V▶ | 16. Synchronizer hub    |
|     | 4. Filler plug         | ◀D▶ | ◀T▶ | 17. Synchronizer ring   |
|     | 5. Gasket              | ◀D▶ | ◀T▶ | 18. 5th speed gear      |
| ◀A▶ | ◀Y▶                    | ◀D▶ | ◀T▶ | 19. Bearing sleeve      |
| ◀A▶ | ◀Y▶                    | ◀D▶ | ◀T▶ | 20. Retaining ring      |
| ◀B▶ | ◀W▶                    | ◀E▶ | ◀U▶ | 21. 5th gear wheel      |
| ◀B▶ | ◀W▶                    | ◀F▶ | ◀S▶ | 22. Locating pin        |
| ◀B▶ | ◀W▶                    | ◀G▶ | ◀R▶ | 23. Cover plate         |
| ◀C▶ | ◀X▶                    | ◀G▶ | ◀R▶ | 24. Poppet spring       |
| ◀C▶ | ◀V▶                    | ◀G▶ | ◀R▶ | 25. Poppet ball         |

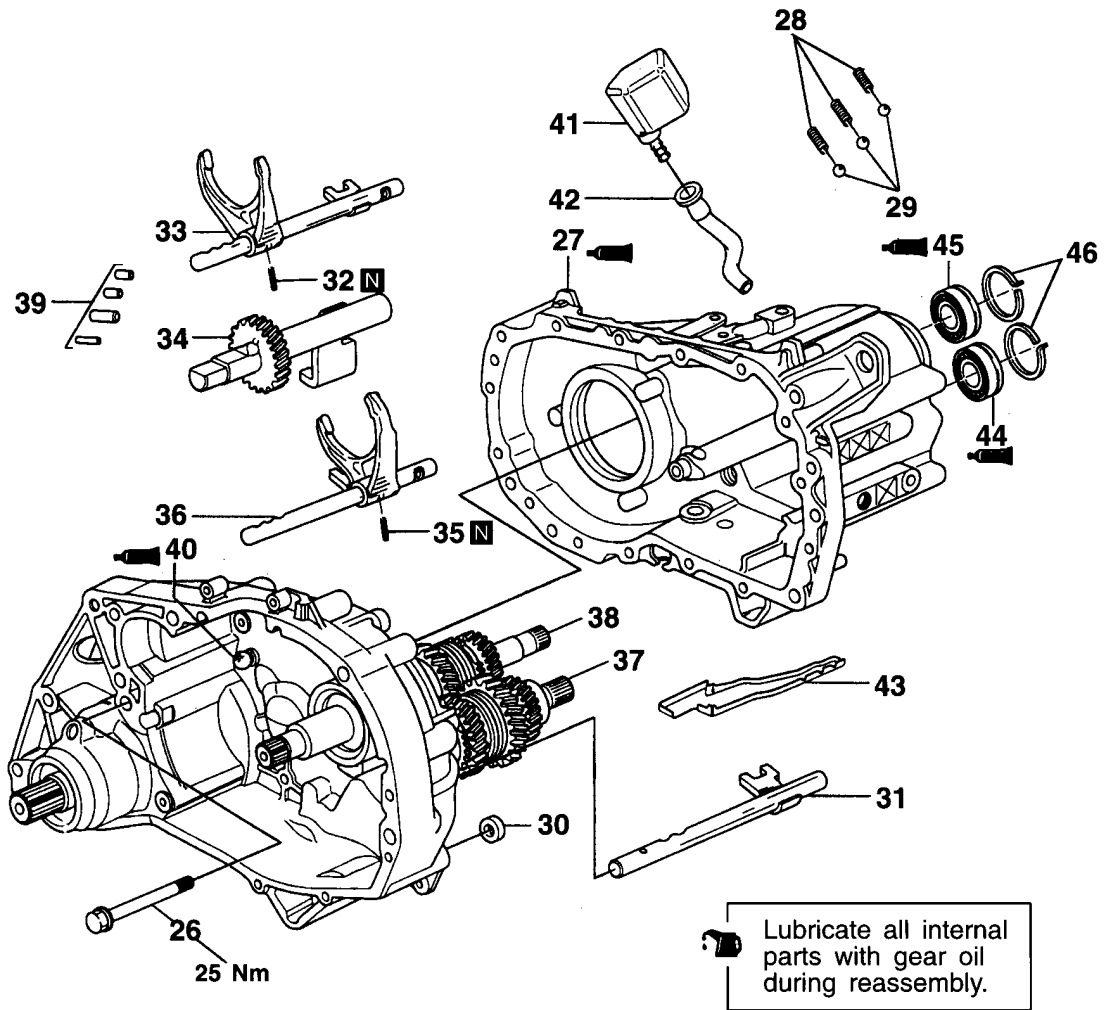

43435

**Disassembly steps**

- |     |     |                                     |
|-----|-----|-------------------------------------|
| ▶H▶ | ▶Q▶ | 26. Bolt                            |
| ▶H▶ | ▶Q▶ | 27. Transmission case               |
| ▶H▶ | ▶Q▶ | 28. Poppet spring                   |
| ▶I▶ | ▶P▶ | 29. Poppet ball                     |
| ▶I▶ | ▶N▶ | 30. Magnet                          |
| ▶J▶ | ▶J▶ | 31. 5th gear shift rail assembly    |
| ▶J▶ | ▶J▶ | 32. Spring pin                      |
| ▶K▶ | ▶K▶ | 33. 1st and 2nd shift rail assembly |
| ▶L▶ | ▶K▶ | 34. Reverse idler gear shaft        |
| ▶L▶ | ▶J▶ | 35. Spring pin                      |
| ▶L▶ | ▶H▶ | 36. 3rd and 4th shift rail assembly |

- |     |     |                               |
|-----|-----|-------------------------------|
| ▶L▶ | ▶H▶ | 37. Output shaft              |
| ▶L▶ | ▶H▶ | 38. Input shaft               |
| ▶N▶ | ▶F▶ | 39. Interlock plungers        |
| ▶O▶ | ▶E▶ | 40. Plastic cover             |
| ▶P▶ | ▶D▶ | 41. Breather unit             |
| ▶P▶ | ▶D▶ | 42. Breather hose             |
| ▶Q▶ | ▶C▶ | 43. Oil guide                 |
| ▶R▶ | ▶A▶ | 44. Output shaft rear bearing |
| ▶R▶ | ▶A▶ | 45. Input shaft rear bearing  |
| ▶R▶ | ▶A▶ | 46. Snap ring                 |

DISASSEMBLY AND REASSEMBLY <F5MR3>

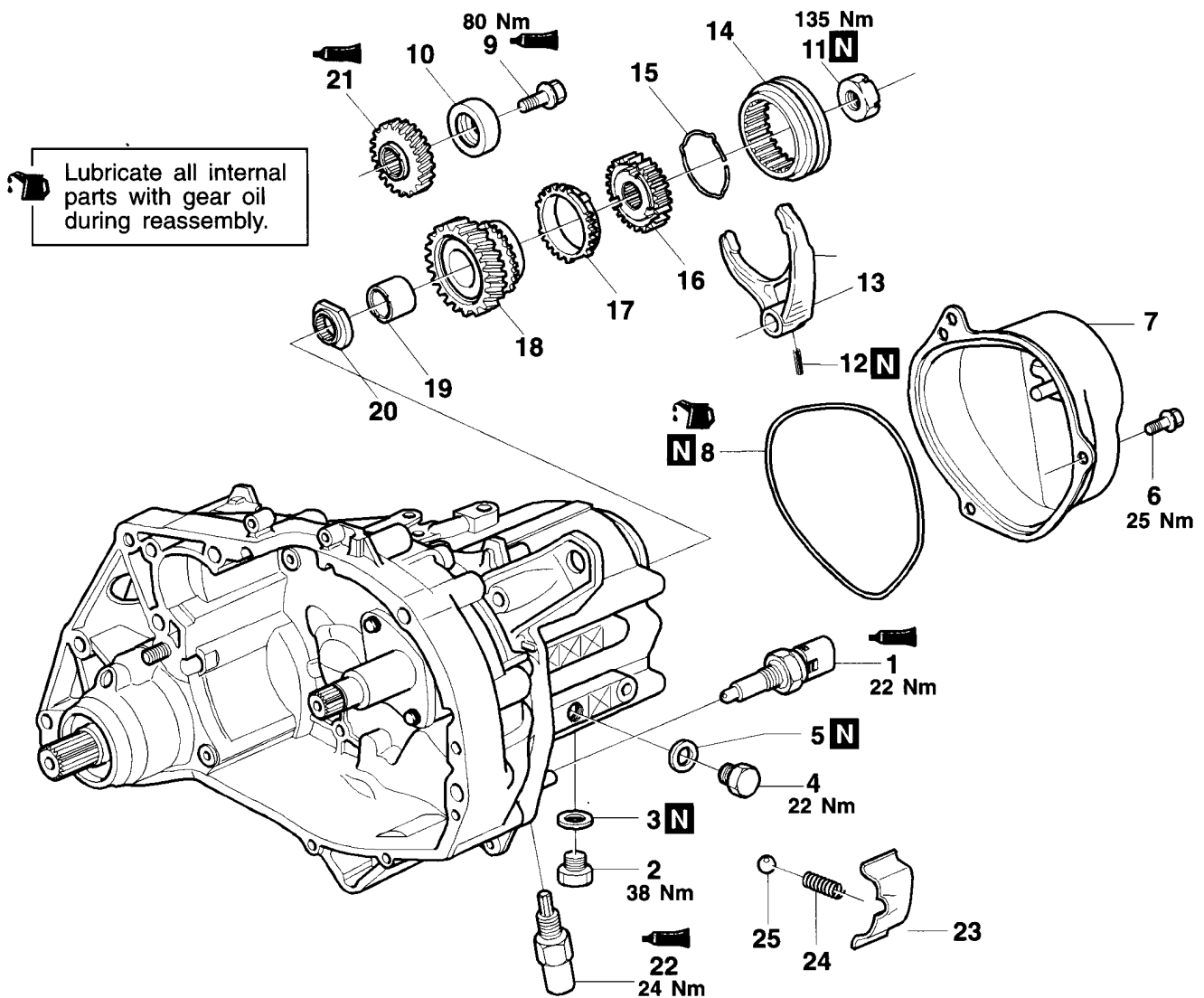

RMT0002

Disassembly steps

- |     |                       |     |     |                         |
|-----|-----------------------|-----|-----|-------------------------|
| ▶Z◀ | 1. Backup lamp switch | ▶C▶ | ▶V▶ | 14. Synchronizer sleeve |
|     | 2. Drain plug         | ▶D▶ | ▶V▶ | 15. Synchronizer spring |
|     | 3. Gasket             | ▶D▶ | ▶V▶ | 16. Synchronizer hub    |
|     | 4. Filler plug        | ▶D▶ | ▶T▶ | 17. Synchronizer ring   |
|     | 5. Gasket             | ▶D▶ | ▶T▶ | 18. 5th speed gear      |
| ▶A▶ | ▶Y▶                   | ▶D▶ | ▶T▶ | 19. Bearing sleeve      |
| ▶A▶ | ▶Y▶                   | ▶E▶ | ▶U▶ | 20. Retaining ring      |
| ▶B▶ | ▶W▶                   | ▶F▶ | ▶S▶ | 21. 5th gear wheel      |
| ▶B▶ | ▶W▶                   | ▶G▶ | ▶R▶ | 22. Locating pin        |
| ▶B▶ | ▶W▶                   | ▶G▶ | ▶R▶ | 23. Cover plate         |
| ▶C▶ | ▶X▶                   | ▶G▶ | ▶R▶ | 24. Poppet spring       |
| ▶C▶ | ▶V▶                   |     | ▶R▶ | 25. Poppet ball         |



Lubricate all internal parts with gear oil during reassembly.

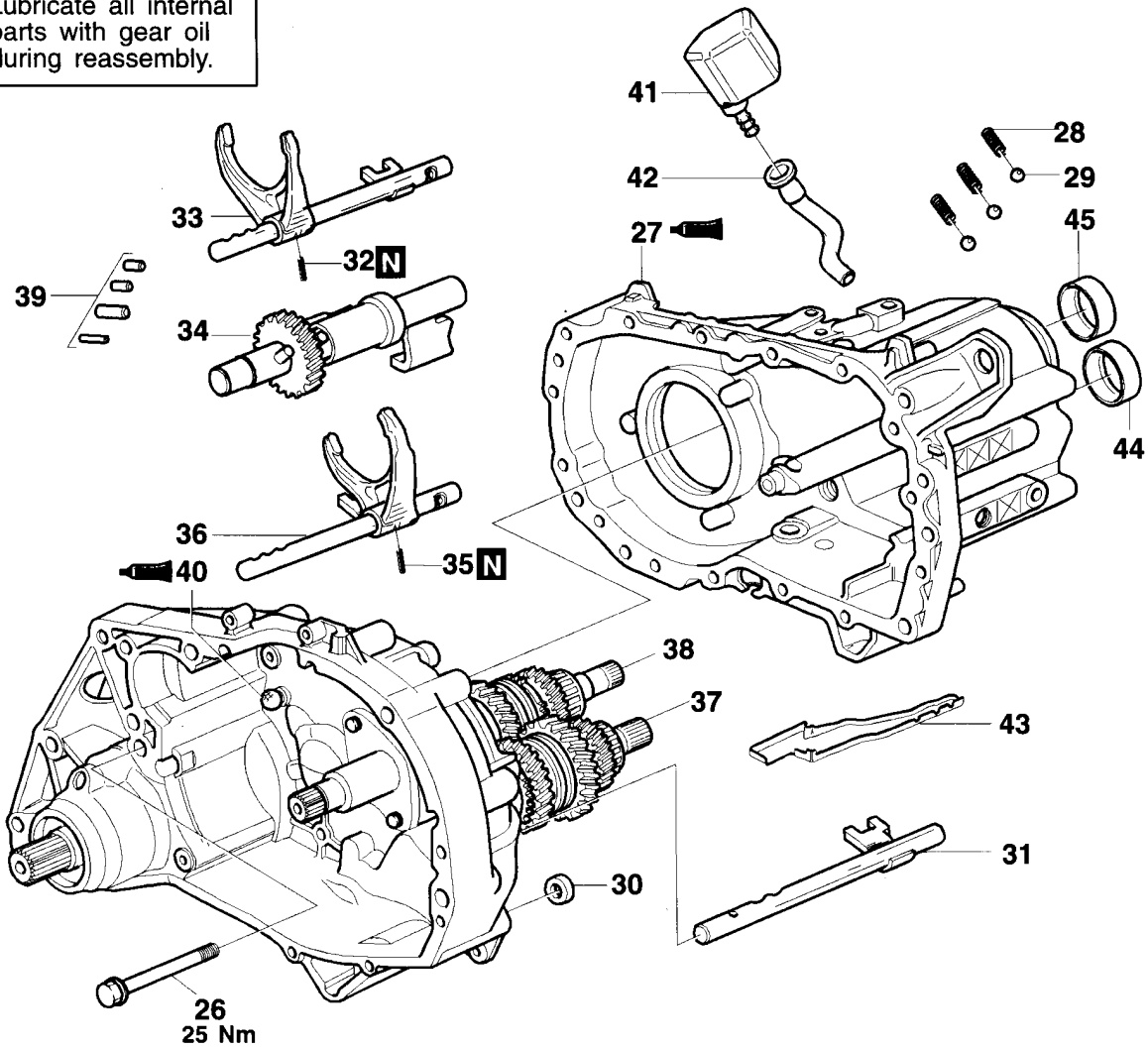

RMT0003

**Disassembly steps**

- ▶H▶ 26. Bolt
- ▶H▶ ▶Q▶ 27. Transmission case
- ▶H▶ ▶Q▶ 28. Poppet spring
- ▶I▶ ▶Q▶ 29. Poppet ball
- ▶J▶ ▶P▶ 30. Magnet
- ▶J▶ ▶N▶ 31. 5th gear shift rail assembly
- ▶J▶ ▶L▶ 32. Spring pin
- ▶K▶ ▶L▶ 33. 1st – 2nd gear shift rail assembly
- ▶K▶ ▶L▶ 34. Reverse idler gear shaft
- ▶K▶ ▶L▶ 35. Spring pin

- ▶M▶ ▶O▶ 36. 3rd – 4th gear shift rail assembly
- ▶M▶ ▶M▶ 37. Output shaft
- ▶N▶ ▶I▶ 38. Input shaft
- ▶O▶ ▶G▶ 39. Interlock plungers
- ▶P▶ ▶E▶ 40. Plastic cover
- ▶P▶ ▶D▶ 41. Breather unit
- ▶Q▶ ▶D▶ 42. Breather hose
- ▶S▶ ▶C▶ 43. Oil guide
- ▶S▶ ▶B▶ 44. Output shaft rear bearing cup
- ▶S▶ ▶B▶ 45. Input shaft rear bearing cup

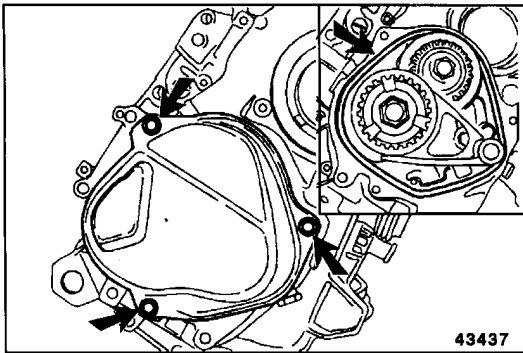

**DISASSEMBLY SERVICE POINTS**

**◀A▶ BOLT/REAR COVER/O-RING REMOVAL**

- (1) Remove the bolts and lift off the rear cover carefully to avoid damaging the oil pipe on the rear cover.
- (2) Remove the O-ring.

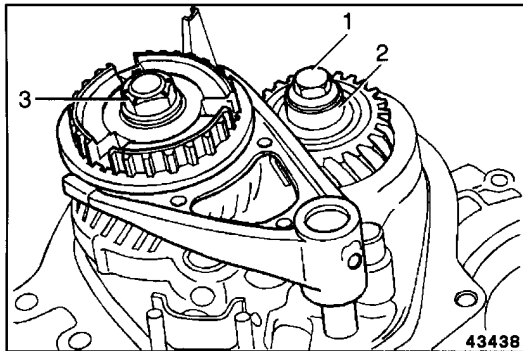

**◀B▶ BOLT/SHIM/LOCK NUT REMOVAL**

- (1) Engage two gears: first engage reverse gear and then push the 5th gear synchronizer sleeve over the 5th speed gear.
- (2) Remove the bolt 1, shim 2 and lock nut 3.

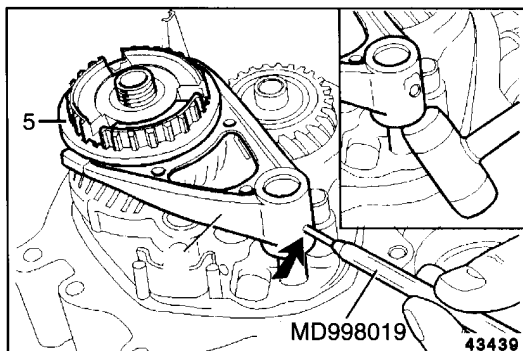

**◀C▶ SPRING PIN/5TH SPEED SHIFT FORK/ SYNCHRONIZER SLEEVE REMOVAL**

- (1) Support the shift rail assembly and remove the spring pin with spring pin extractor MD998019.
- (2) Tap the 5th speed shaft fork 4 together with the synchronizer 5 off the shift rail assembly.

**NOTE**

Do not lose the spring pin.

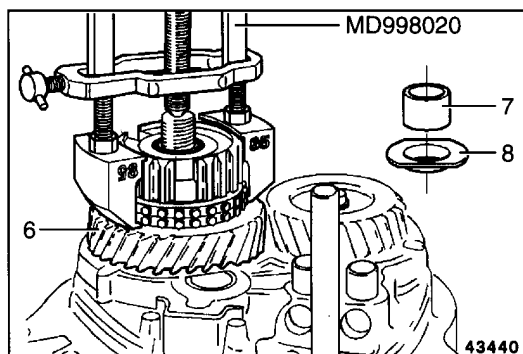

**◀D▶ SYNCHRONIZER HUB/SYNCHRONIZER RING/ SYNCHRONIZER SPRING/5TH SPEED GEAR/ BEARING SLEEVE/RETAINING RING REMOVAL**

- (1) Locate bearing puller MD998020 with attachments No.85 under the teeth of the synchronizer hub.
- (2) Pull the synchronizer hub off the shaft.
- (3) Remove the 5th speed gear 6, bearing sleeve 7 and retaining ring 8.

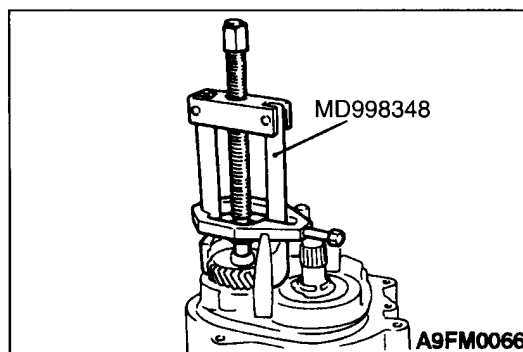

**◀E▶ 5TH GEAR WHEEL REMOVAL**

- (1) Locate gear puller MD998348 over the 5th gear wheel.
- (2) Pull the gear wheel off the shaft.

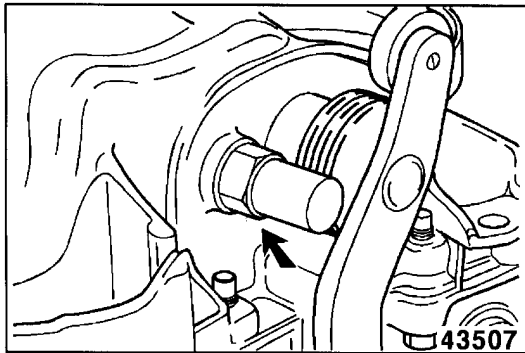

#### ◀F▶ LOCATING PIN REMOVAL

Unscrew and remove the locating pin.

##### NOTE

Do not lose the adjusting ring (if fitted).

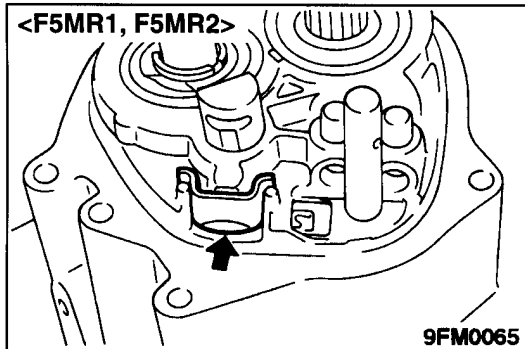

#### ◀G▶ COVER PLATE/POPPET SPRING/POPPET BALL REMOVAL

Remove the cover plate and withdraw the poppet spring and ball.

##### NOTE

Do not lose the poppet spring and ball.

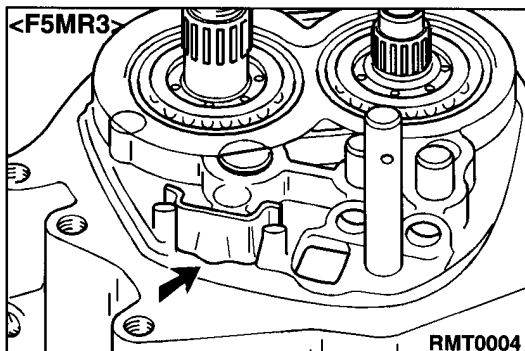

#### ◀H▶ TRANSMISSION CASE/POPPET BALL/POPPET SPRING REMOVAL

- (1) Remove the retaining bolts.
- (2) Tap lightly to separate the transmission case and clutch housing.
- (3) Remove the transmission case; note the shim on the output shaft.

##### NOTE

When removing the transmission case, hold the poppet springs and balls of both selector shafts in position with two hex nut drivers.

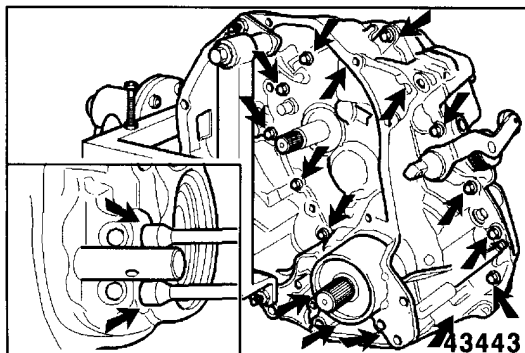

#### ◀I▶ MAGNET/5TH GEAR SHIFT RAIL ASSEMBLY REMOVAL

- (1) Remove the magnet from the clutch housing.
- (2) Remove the shift rail assembly 9 from the transmission case.

##### NOTE

Catch the poppet spring and ball and put them to one side.

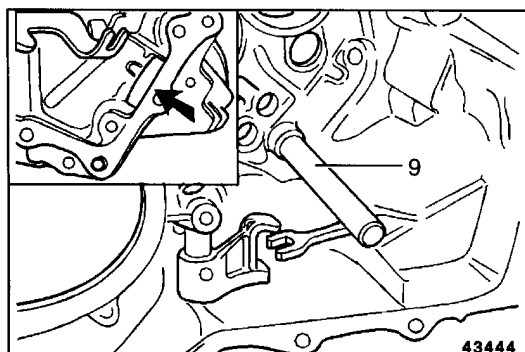

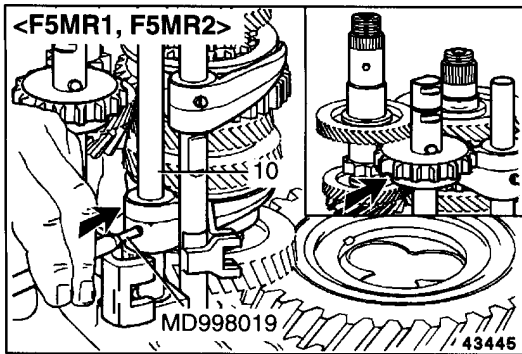

**◀J▶ SPRING PIN/1ST AND 2ND GEAR SHIFT RAIL ASSEMBLY REMOVAL**

- (1) Cover the differential drive gear with a cleaning rag.
- (2) Tap out the spring pin as far as possible with spring pin extractor MD998019.
- (3) Move 3rd and 4th gear into neutral.
- (4) Raise the reverse gear shaft as high as possible and remove the shift rail assembly 10.

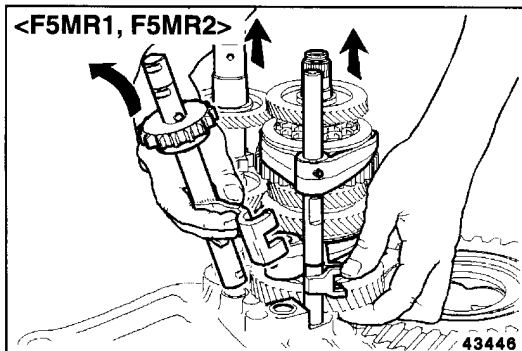
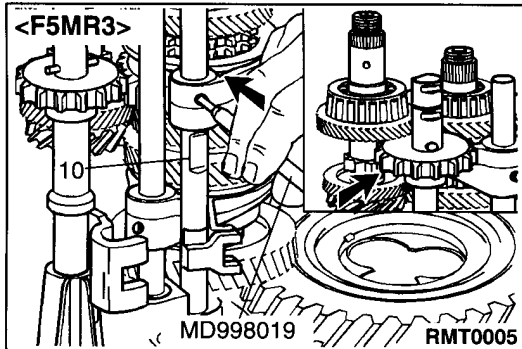

**◀K▶ REVERSE IDLER GEAR SHAFT REMOVAL**

- (1) Raise the input and output shafts.
- (2) Take the reverse idler gear shaft out of the clutch housing.

**NOTE**

Hold the output shaft at the bottom.

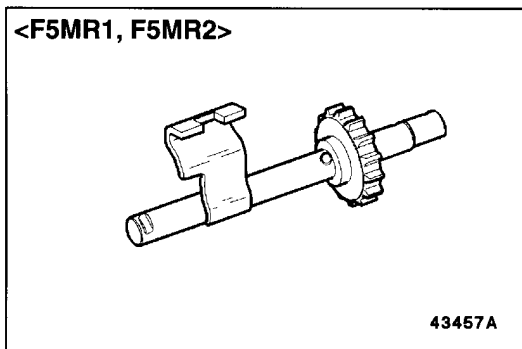
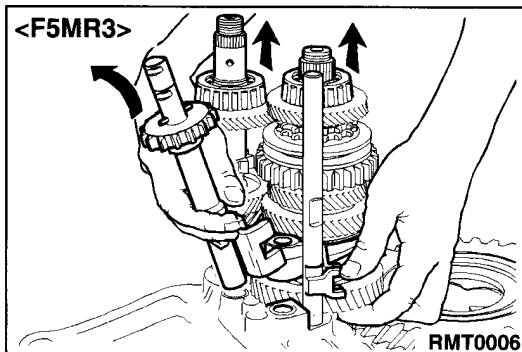

- (3) Inspect the reverse idler gear shaft.

**NOTE**

The shaft must always be renewed in the event of wear or damage. The shaft cannot be reconditioned.



&lt;F5MR3&gt;

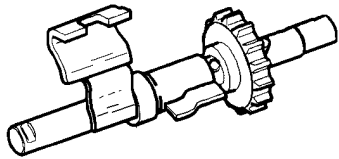

RMT0007

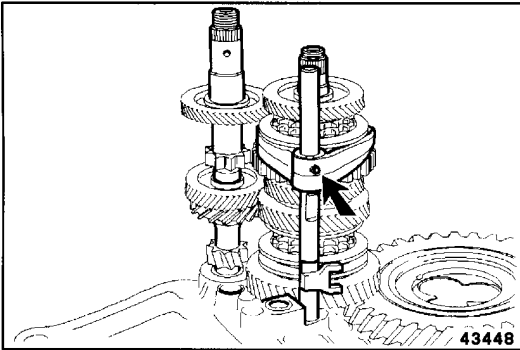

43448

#### ◀L▶ SPRING PIN/3RD AND 4TH SHIFT RAIL ASSEMBLY/ INPUT SHAFT/OUTPUT SHAFT REMOVAL

- (1) Remove the spring pin from the 3rd and 4th gear selector fork.
- (2) Take both shafts together with the shift rail assembly out of the clutch housing.

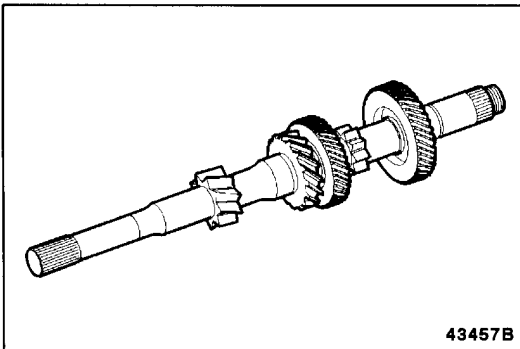

43457B

- (3) Inspect the input shaft.

#### NOTE

The shaft must always be renewed in the event of wear or damage. The shaft cannot be reconditioned.

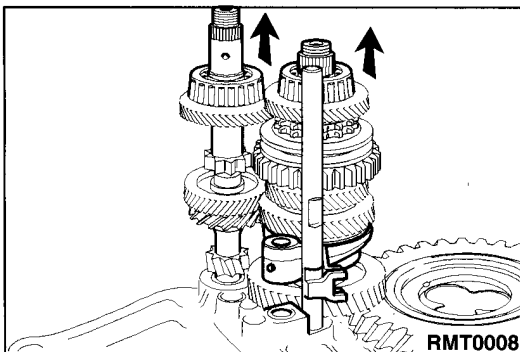

RMT0008

#### ◀M▶ INPUT SHAFT/OUTPUT SHAFT REMOVAL

- (1) Take the two shafts out of the clutch housing together.

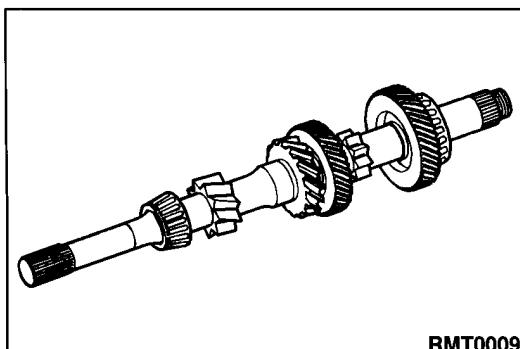

RMT0009

- (2) Inspect the input shaft.

#### NOTE

The shaft must always be replaced in the event of wear or damage. The shaft cannot be reconditioned.

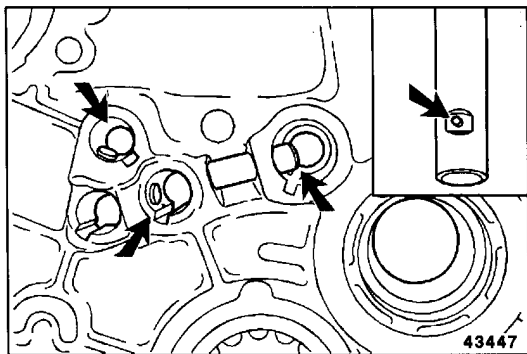

**◀N▶ INTERLOCK PLUNGERS REMOVAL**

Remove the three interlock plungers and the small interlock plunger from the 1st and 2nd gear shift rail assembly.

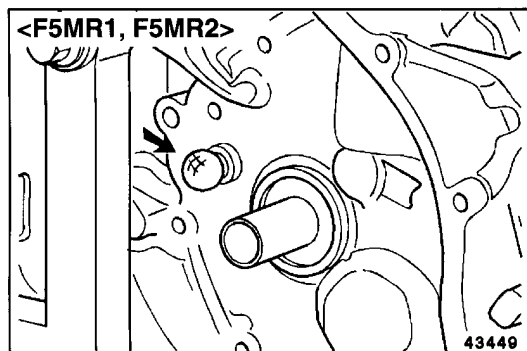

**◀O▶ PLASTIC COVER REMOVAL**

Remove the plastic cover from the release fork ball and socket joint.

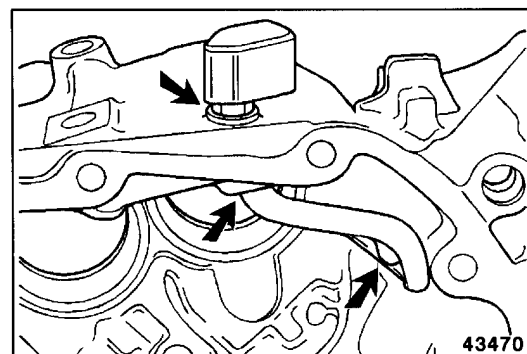
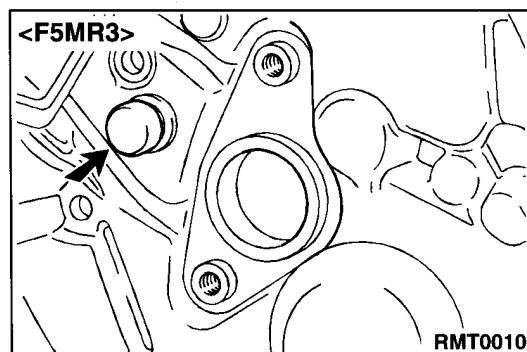

**◀P▶ BREATHER UNIT/BREATHER HOSE REMOVAL**

Take the breather unit out of the transmission case. Carefully remove the breather hose.

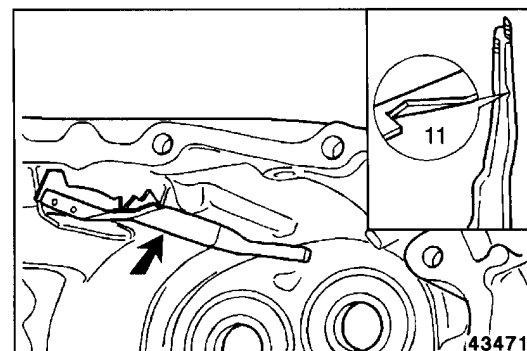

**◀Q▶ OIL GUIDE REMOVAL**

Push in the lug 11 and withdraw the oil guide from the transmission case.

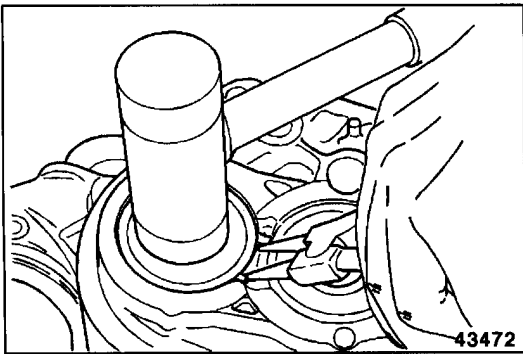

**◀R> OUTPUT SHAFT REAR BEARING/INPUT SHAFT REAR BEARING/SNAP RING REMOVAL**

- (1) Open the snap rings with a pair of pliers.
- (2) Tap out the bearings towards the inside of the transmission case with a plastic-tip hammer.
- (3) Remove the two snap rings.

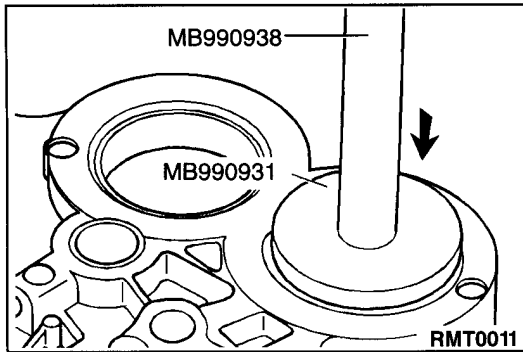

**◀S> REAR BEARING CUP OUTPUT SHAFT/REAR BEARING CUP INPUT SHAFT REMOVAL**

- (1) Tap the bearing cups out of the transmission case with handle MB990938 and bearing installer MB990931.

**ADJUSTMENT BEFORE REASSEMBLY  
<F5MR3>**

**CALCULATE THE PRE-TENSION OF THE INPUT AND OUTPUT SHAFTS WITH NEW BEARINGS**

- (1) Introduce the input shaft and the output shaft in the clutch housing.
- (2) Place the transmission case on the clutch housing, insert a few retaining bolts around the shafts and tighten the bolts.
- (3) Locate the mounting plate MB996012 on the tripod joint housing and secure it with a bolt.
- (4) Locate the magnetic base together with clock gauge on the mounting plate.

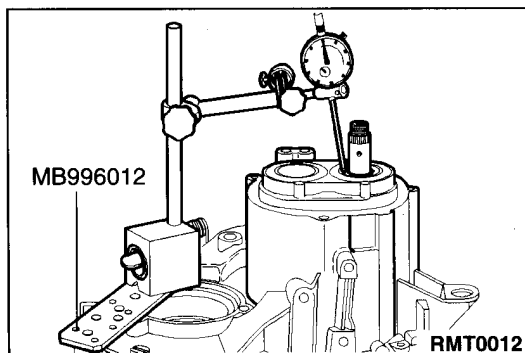

Input shaft

- (5) Rotate the input shaft a few times.
  - (6) Raise the input shaft at the clutch end and read off the value indicated by the clock gauge.
- Repeat this operation several times.

Example	A	B
	new bearings	used bearings
pre-tension value	0.00 mm	-0.03 mm
shim thickness	+0.60 mm	+0.60 mm
measured value	+0.46 mm	+0.46 mm
	<u>          </u>	<u>          </u>
	=1.06 mm	=1.03 mm

Select:

- A: a shim with a thickness of 1.10 mm
- B: a shim with a thickness of 1.50 mm

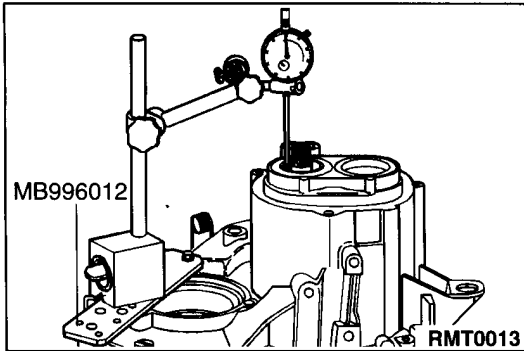

Output shaft

- (7) Rotate the output shaft a few times.
- (8) Raise the output shaft at the clutch end and read off the value indicated by the clock gauge.  
Repeat this operation several times.

Example	A	B
	new bearings	used bearings
pre-tension value	0.26 mm	0.06 mm
shim thickness	+1.60 mm	+1.60 mm
measured value	+0.28 mm	+0.28 mm
	<u>=2.14 mm</u>	<u>=1.94 mm</u>

Select:

A: a shim with a thickness of 2.15 mm

B: a shim with a thickness of 1.95 mm

NOTE

Always use the thickest shim in order to obtain the required pre-tension value.

- (9) Remove the transmission case and the input shaft and output shaft.

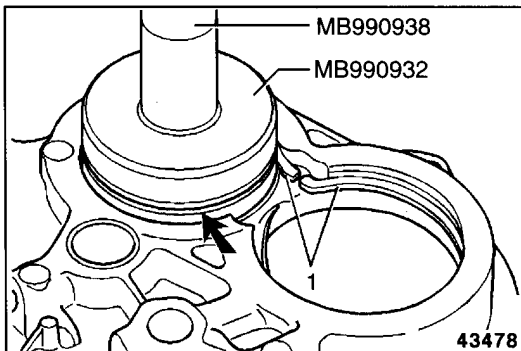

REASSEMBLY SERVICE POINTS

▶A◀ SNAP RING/INPUT SHAFT REAR BEARING/OUTPUT SHAFT REAR BEARING INSTALLATION

- (1) Coat the mating faces in the transmission case with the specified sealant.
- (2) Locate the two snap rings 1.
- (3) Introduce the bearings from the outside of the transmission case with the groove facing up.
- (4) Open the snap rings with a pair of pliers and tap in the bearings with a plastic-tip hammer until they are projecting about 3 mm above the transmission case.
- (5) Remove the pliers.
- (6) Now tap the bearings further into the transmission case with handle MB990938 and bearing installer set MB990932 until the snap rings slip into the grooves.

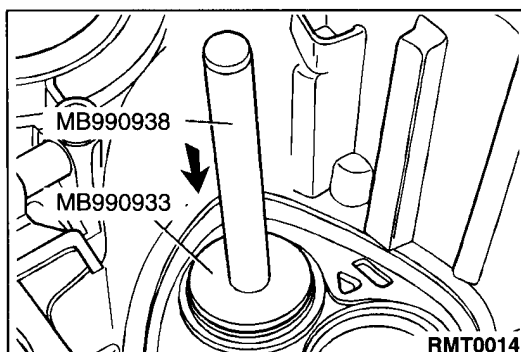

▶B◀ INPUT SHAFT REAR BEARING CUP/OUTPUT SHAFT REAR BEARING CUP INSTALLATION

- (1) Coat the mating faces in the transmission case with the specified sealant.
- (2) Introduce the bearing cups from the inside of the transmission case.
- (3) Tap the bearing cup into the transmission case as far as the stop with handle MB990938 and installer MB990933.

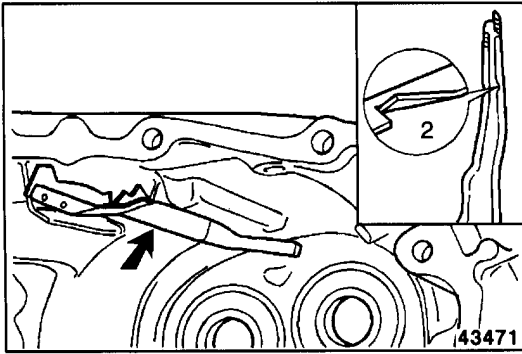
**▶C◀ OIL GUIDE INSTALLATION**

Locate the oil guide in the transmission case.

**Caution**

**Make sure that the locking lug 2 of the oil guide is correctly positioned.**

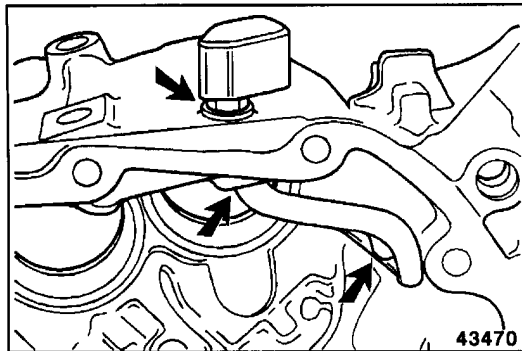
**▶D◀ BREATHER HOSE/BREATHER UNIT INSTALLATION**

Push the breather hose into the transmission case. Fit the breather unit.

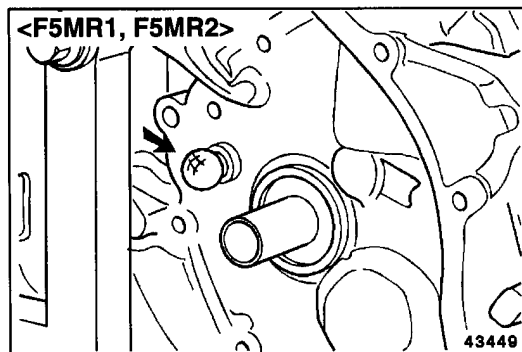
**▶E◀ PLASTIC COVER INSTALLATION**

- (1) Thoroughly clean the ball and socket joint.
- (2) Apply Loctite 415 to the ball joint.
- (3) Fit a new plastic cover on the ball and socket joint (press down firmly).

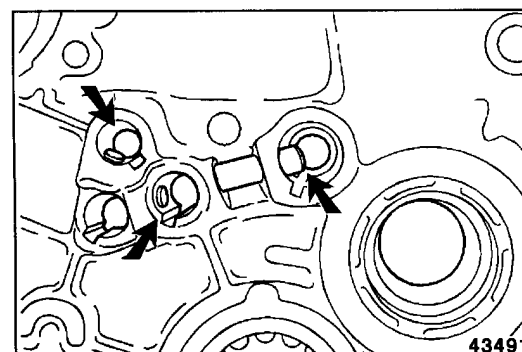
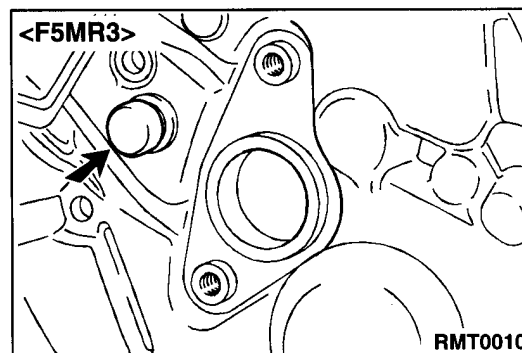
**▶F◀ INTERLOCK PLUNGERS INSTALLATION**

Fit the three interlock plungers.

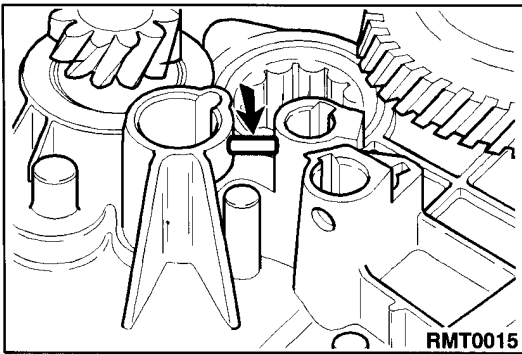

**►G◄ INTERLOCK PLUNGER INSTALLATION**

- (1) Fit the dowel pin.

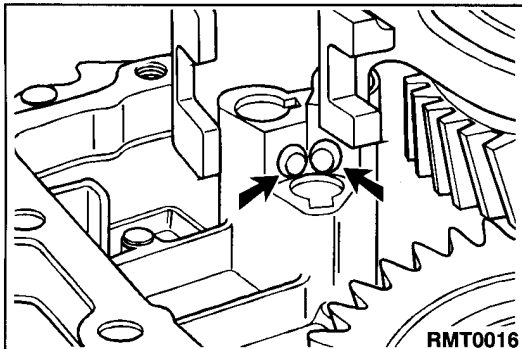

- (2) Fit the two short interlock plungers.

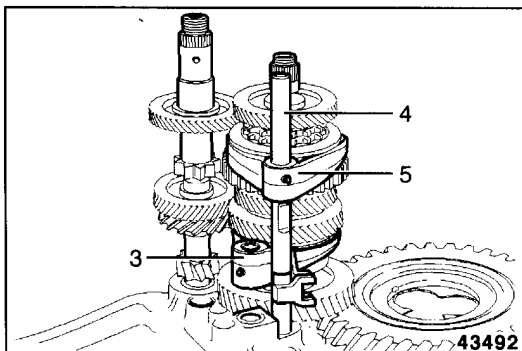

**►H◄ INPUT SHAFT/OUTPUT SHAFT/3RD AND 4TH SHIFT RAIL ASSEMBLY INSTALLATION**

- (1) Locate the 1st and 2nd gear selector fork 3 in the synchronizer hub.
- (2) Locate the shift rail assembly 4 together with the selector fork 5 in the synchronizer sleeve.
- (3) Locate the three shafts in the clutch housing.

**NOTE**

When fitting the input shaft, take care not to damage the oil seal.

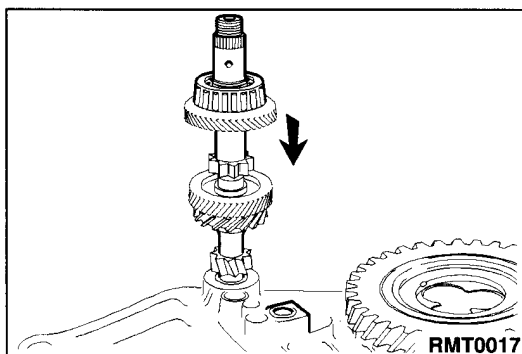

**►I◄ INPUT SHAFT INSTALLATION**

**NOTE**

When fitting the input shaft, take care not to damage the oil seal.

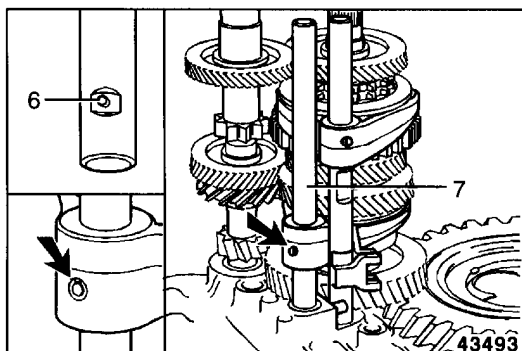

**►J◄ 1ST AND 2ND SHIFT RAIL ASSEMBLY/SPRING PIN INSTALLATION**

- (1) Fit the small interlock plunger 6 in the shift rail assembly.
- (2) Introduce the shift rail assembly 7 through the selector fork in the housing.
- (3) Check the operation of the interlock plungers.
- (4) Fit a new (short) spring pin in the selector fork.

**NOTE**

The slit in the spring pin must be in axial alignment with the shift rail assembly.

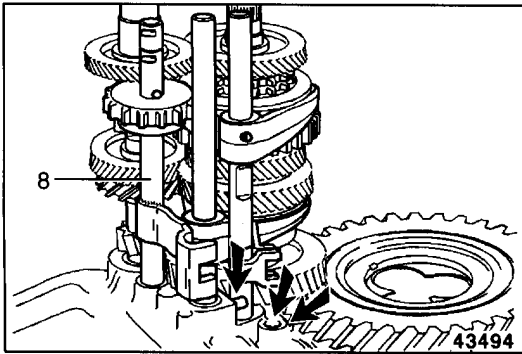

### ►K◄ REVERSE IDLER GEAR SHAFT INSTALLATION

- (1) Raise the input and output shafts slightly.
- (2) Locate the reverse idler gear shaft 8.
- (3) Put the shafts into neutral so that the interlock plungers are lying clear.

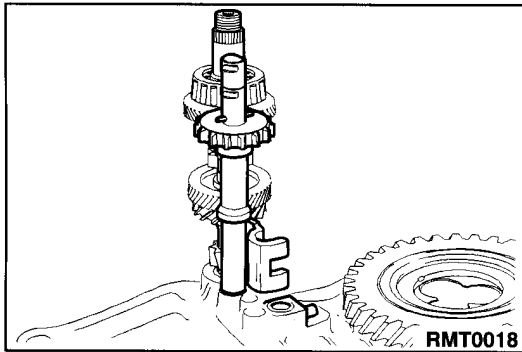

### ►L◄ REVERSE IDLER GEAR SHAFT INSTALLATION

- (1) Raise the input shaft slightly.
- (2) Locate the reverse idler gear shaft.

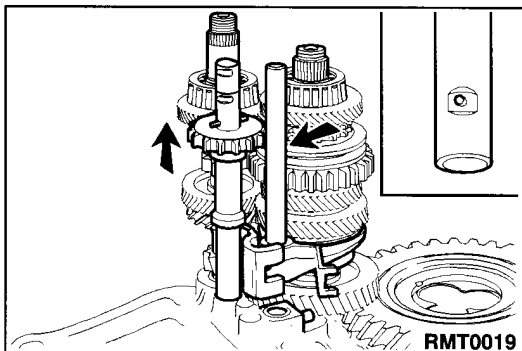

### ►M◄ OUTPUT SHAFT INSTALLATION

- (1) Fit the small dowel pin in the shift rail assembly.
- (2) Raise the reverse idler gear shaft slightly and push the long dowel pin into the hole.
- (3) Locate the shift rail assembly together with the 1st and 2nd gear shift fork in the synchronizer sleeve.
- (4) Locate the two shafts in the clutch housing.

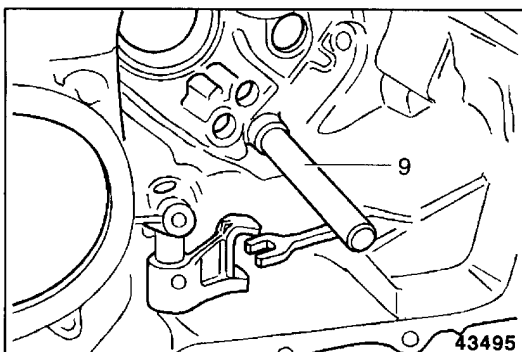

### ►N◄ 5TH GEAR SHIFT RAIL ASSEMBLY INSTALLATION

- (1) Locate the shift rail assembly 9.
- (2) Fit the poppet spring and ball.
- (3) Depress the ball and raise the shift rail assembly until the ball engages the second recess (neutral position).

#### NOTE

Put the shift rail assembly into neutral so that the interlock plungers are lying clear.

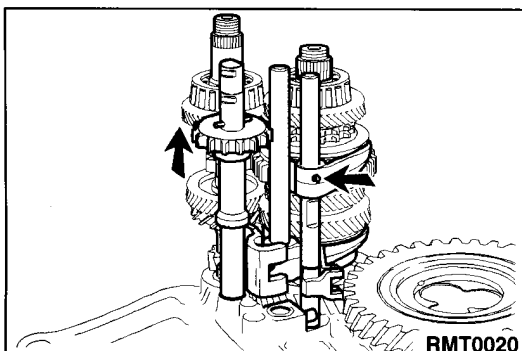

### ►O◄ 3RD/4TH GEAR SHIFT RAIL ASSEMBLY INSTALLATION

- (1) Raise the reverse idler gear shaft slightly.
- (2) Locate the shift rail assembly together with the 3rd and 4th gear shift fork in the synchronizer sleeve.
- (3) Locate the shaft in the clutch housing.  
Fit a new spring pin in the shift fork (it must be fully inserted in the shift fork).

#### NOTE

The slit in the spring pin must be in axial alignment with the shift rail assembly.

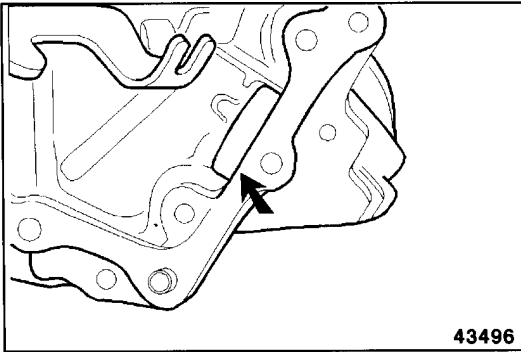

►P◄ MAGNET INSTALLATION

Fit the magnet in the differential housing.

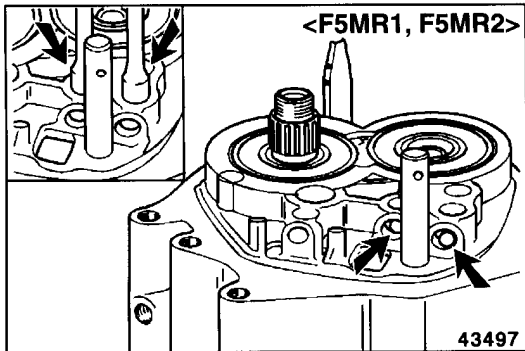

►Q◄ POPPET BALL/POPPET SPRING/TRANSMISSION CASE INSTALLATION

- (1) Apply liquid gasket cement (Loctite 518) to the mating face.

NOTE

Do not apply too much gasket cement. Let the gasket cement dry for at least thirty minutes before filling the manual transmission with oil.

- (2) Locate the transmission case over the shafts.
- (3) Locate the balls and poppet springs for the 1st, 2nd, 3rd and 4th gear shift rail assemblies, using two hex nut drivers.
- (4) Now press the transmission case on to the mating face, insert some of the retaining bolts and secure them finger-tight.

NOTE

If necessary, push up the 5th gear shift rail assembly a short distance.

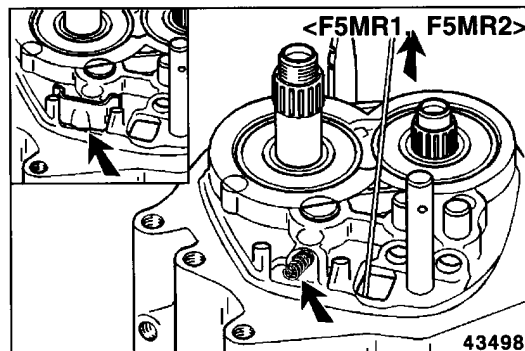
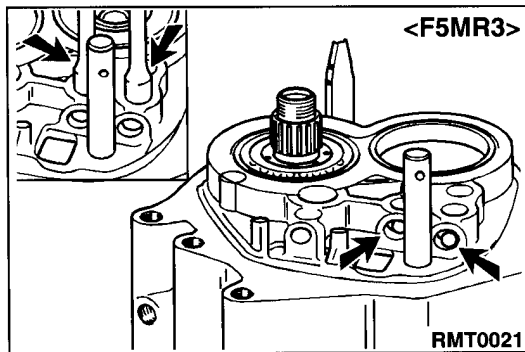

►R◄ POPPET BALL/POPPET SPRING/COVER PLATE INSTALLATION

- (1) Pull the reverse idler gear shaft upwards with a wire hook.
- (2) Locate the ball and poppet spring and fit the retainer plate (with the bulge underneath).

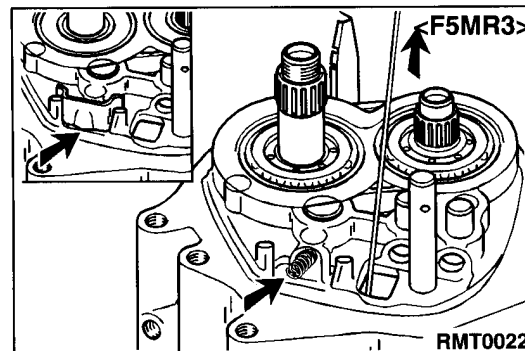



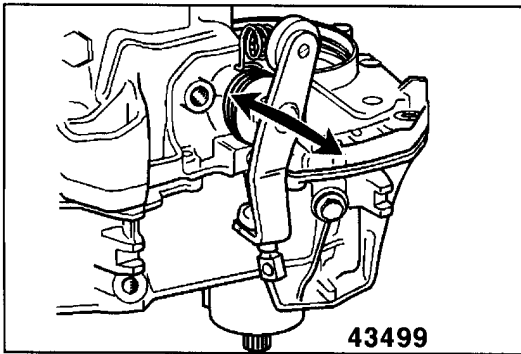

- (3) Rotate the input shaft and check whether the remote control arm can move freely.
- (4) Check that all the gears can be engaged and disengaged.

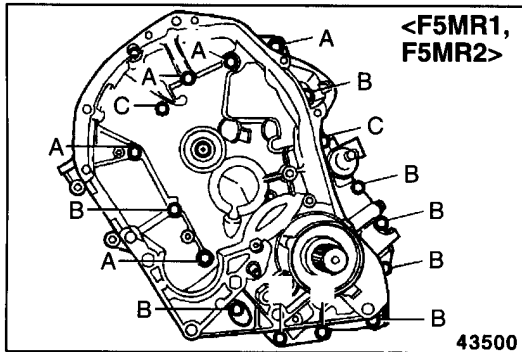

- (5) Fit the bolts as shown in the illustration.

**NOTE**

The bolts have three different lengths:

A = long (45 mm)

B = medium (40 mm)

C = short (35 mm)

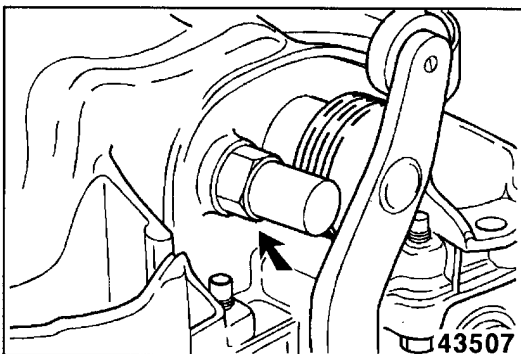
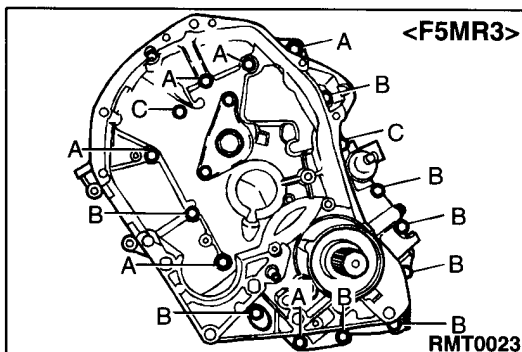
**▶S◀ LOCATING PIN INSTALLATION**

- (1) Apply sealant (Loctite 572) to the locating pin.
- (2) Fit and tighten the locating pin.

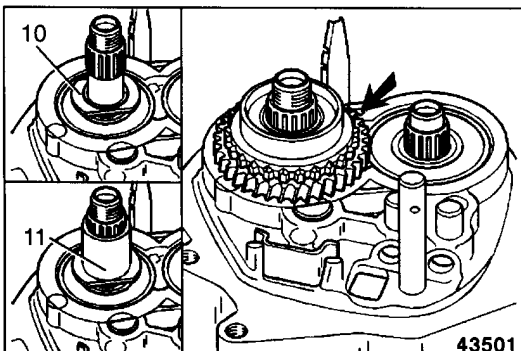
**▶T◀ RETAINING RING/BEARING SLEEVE/5TH SPEED GEAR/SYNCHRONIZER RING INSTALLATION**

- (1) Locate the retaining ring 10 on the shaft with the collar facing towards the bearing.
- (2) Locate the bearing sleeve 11 over the input shaft.
- (3) Locate the 5th speed gear together with the synchronizer ring over the shaft.

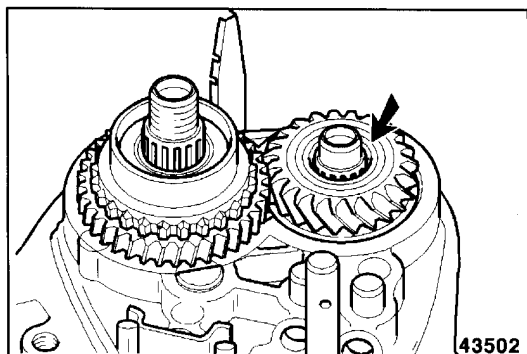

►U◀ 5TH GEAR WHEEL INSTALLATION

- (1) Apply a few drops of sealant (Loctite 242) to the gear wheel.
- (2) Fit the gear wheel on the shaft.
- (3) Press the gear wheel with the bolt and shim on to the output shaft.
- (4) Remove the bolt and shim.

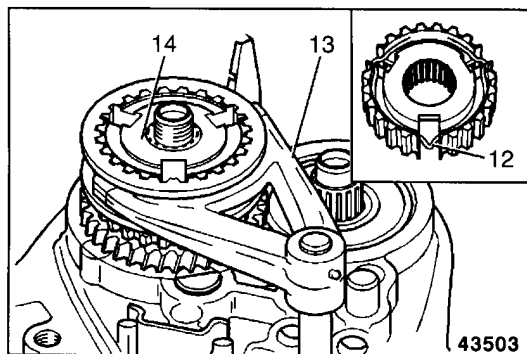

►V◀ SYNCHRONIZER HUB/SYNCHRONIZER SPRING/SYNCHRONIZER SLEEVE/5TH SPEED SHIFT FORK INSTALLATION

- (1) Fit the hub in the synchronizer sleeve.
- (2) Locate the synchronizer spring 12 at the bottom in the recess.
- (3) Locate the selector fork 13 in the synchronizer hub 14 with the long side facing towards the transmission case.
- (4) Fit the hub over the input shaft and at the same time slide the selector fork over the shift rail assembly.
- (5) Press the hub on to the input shaft with the old lock nut.
- (6) Remove the lock nut.

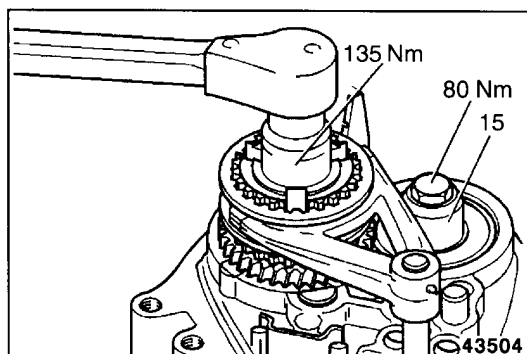

►W◀ LOCK NUT/SHIM/BOLT INSTALLATION

- (1) Press the synchronizer hub into 5th gear.
- (2) Push down the reverse idler gear shaft.
- (3) Fit and tighten a new lock nut.
- (4) Locate the shim 15.
- (5) Apply a few drops of sealant (Loctite 242) to the bolt.
- (6) Fit and tighten the bolt.

NOTE

Put the gears in neutral.

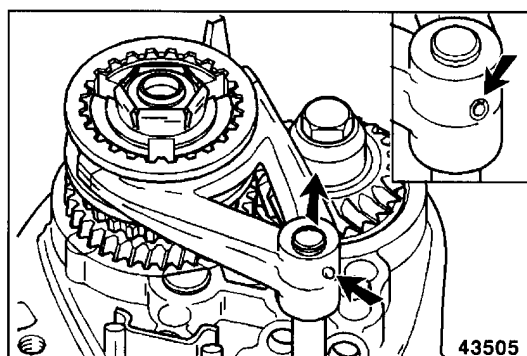

►X◀ SPRING PIN INSTALLATION

- (1) Raise the selector fork.
- (2) Fit a new (long) spring pin in the selector fork.
- (3) Tap in the spring pin to its full extent.

NOTE

The slit in the spring pin must be in axial alignment with the reverse idler gear shaft.

- (4) Check for correct operation.

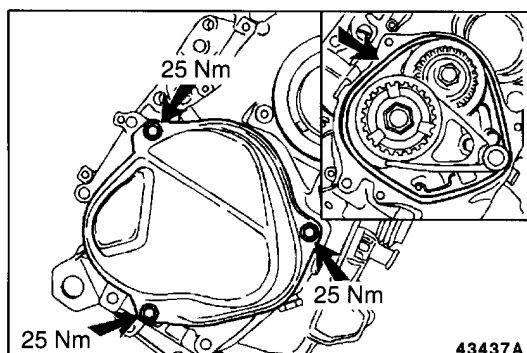

►Y◀ O-RING/REAR COVER/BOLT INSTALLATION

- (1) Place a new O-ring on the transmission case.
- (2) Locate the rear cover carefully on account of the oil guide.
- (3) Fit and tighten the bolts.

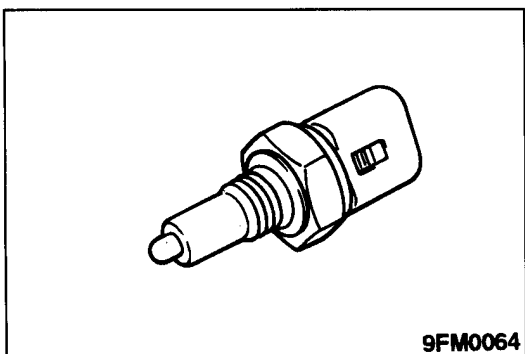
**▶Z◀ BACK-UP LAMP SWITCH INSTALLATION**

- (1) Apply sealant (Loctite 572) to the back-up lamp switch.
- (2) Fit and tighten the back-up lamp switch.

## 4. OUTPUT SHAFT

### DISASSEMBLY AND REASSEMBLY <F5MR1, F5MR2>

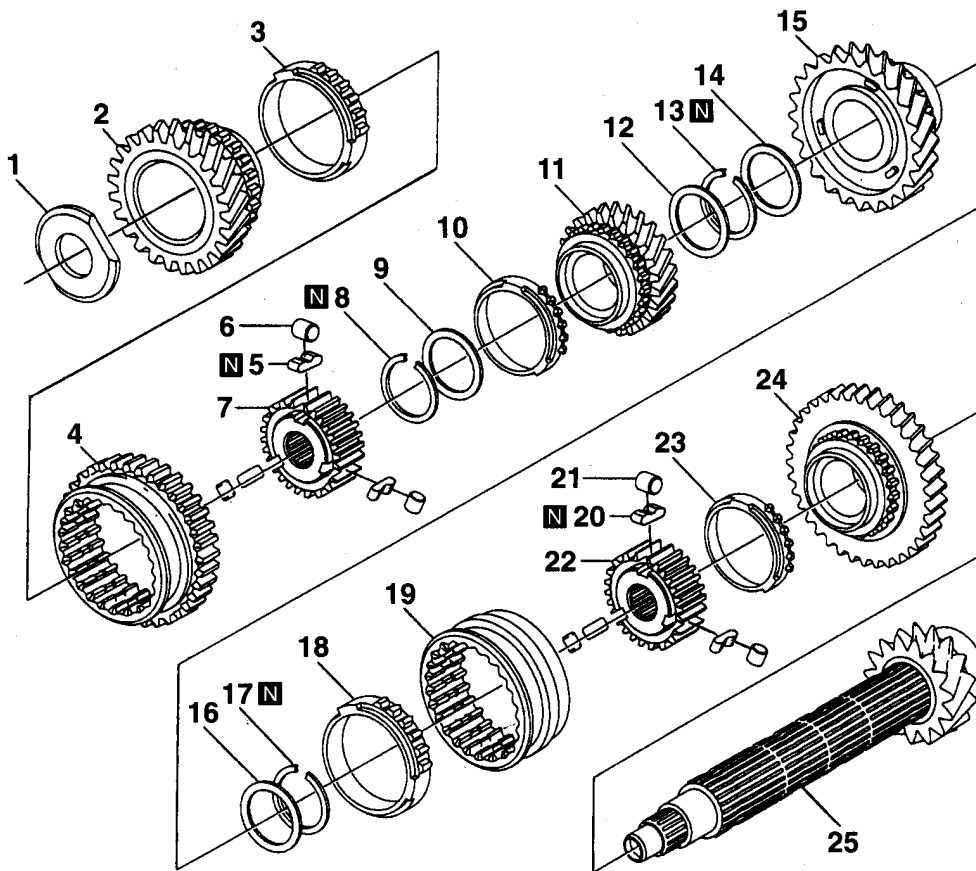

 Lubricate all internal parts with gear oil during reassembly.

43512

#### Disassembly steps

- ◀A▶ ▶N▶ 1. Shim
- ◀A▶ ▶N▶ 2. 4th gear wheel
- ◀A▶ ▶N▶ 3. Synchronizer ring
- ◀G▶ 4. 3rd – 4th synchronizer sleeve
- ◀G▶ 5. Synchronizer springs
- ◀B▶ ▶K▶ 6. Rollers
- ◀B▶ ▶K▶ 7. 3rd – 4th synchronizer hub
- ◀B▶ ▶K▶ 8. Snap ring
- ◀B▶ ▶K▶ 9. Serrated ring
- ◀C▶ ▶I▶ 10. Synchronizer ring
- ◀C▶ ▶I▶ 11. 3rd gear wheel
- ◀C▶ ▶I▶ 12. Serrated ring
- ◀C▶ ▶I▶ 13. Snap ring

- ◀D▶ ▶F▶ 14. Serrated ring
- ◀D▶ ▶F▶ 15. 2nd gear wheel
- ◀D▶ ▶F▶ 16. Serrated ring
- ◀D▶ ▶F▶ 17. Snap ring
- ◀D▶ ▶F▶ 18. Synchronizer ring
- ◀D▶ ▶F▶ 19. 1st – 2nd synchronizer sleeve
- ◀G▶ 20. Synchronizer springs
- ◀G▶ 21. Rollers
- ◀E▶ ▶D▶ 22. 1st – 2nd synchronizer hub
- ◀E▶ ▶D▶ 23. Synchronizer ring
- ◀F▶ ▶A▶ 24. 1st gear wheel
- ◀F▶ ▶A▶ 25. Output shaft

DISASSEMBLY AND REASSEMBLY <F5MR3>

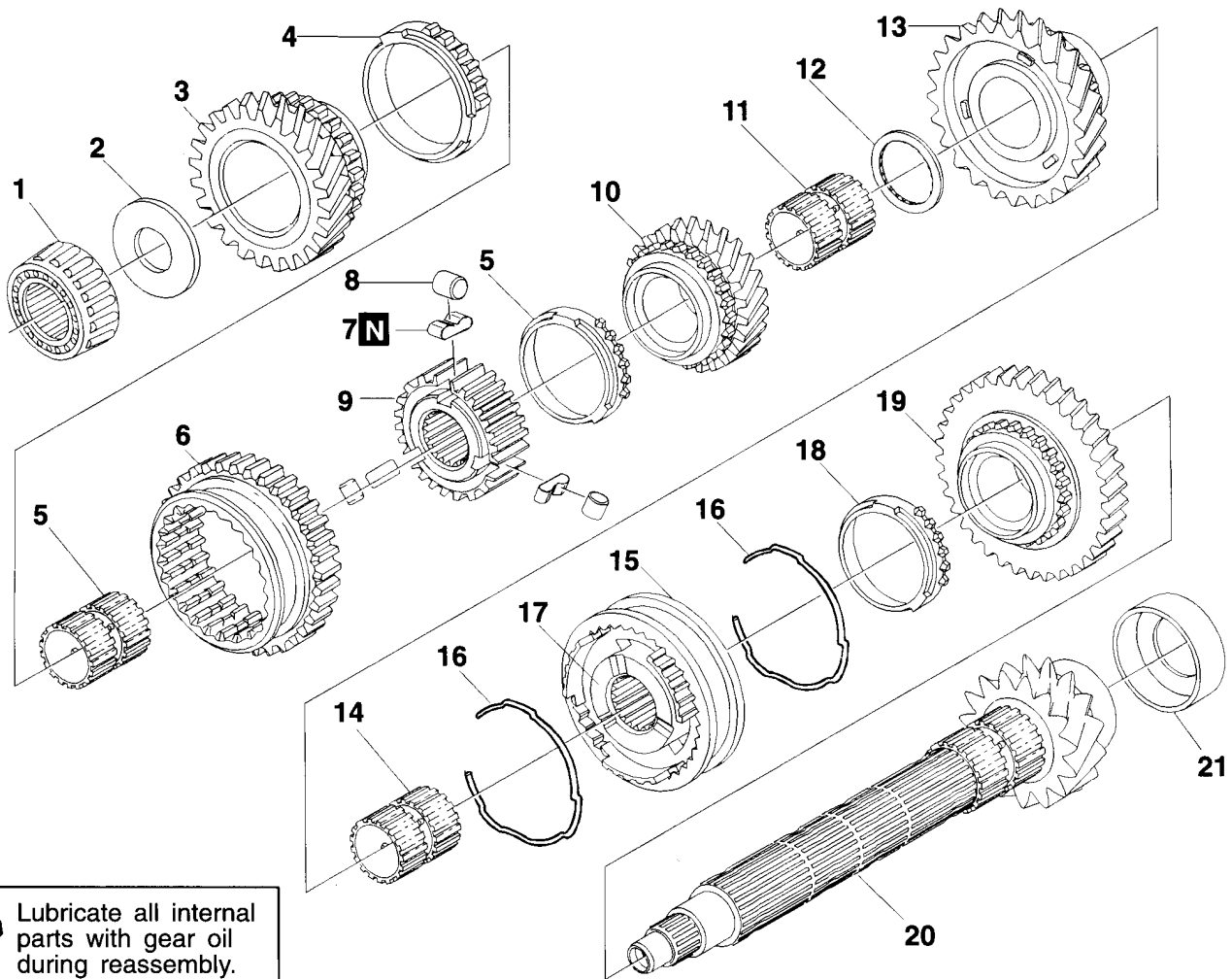

RMT0024

**Disassembly steps**

- |         |                                       |         |  |
|---------|---------------------------------------|---------|--|
|         | 1. Bearing                            |         | 12. Shim                               |
|         | 2. Shim                               |         | 13. 2nd gear wheel                     |
| ◀A▶ ▶O▶ | 3. 4th gear wheel                     | ◀H▶ ▶G▶ | 14. Bearing bushing                    |
|         | 4. Synchronizer ring                  | ◀H▶ ▶E▶ | 15. 1st – 2nd gear synchronizer sleeve |
| ◀H▶ ▶M▶ | 5. Bearing bushing                    | ◀I▶ ▶B▶ | 16. Synchronizer spring                |
|         | 6. 3rd – 4th gear synchronizer sleeve | ◀H▶ ▶D▶ | 17. 1st – 2nd gear synchronizer hub    |
| ◀I▶     | 7. Synchronizer spring                |         | 18. Synchronizer ring                  |
|         | 8. Roller                             | ◀H▶ ▶A▶ | 19. 1st gear wheel                     |
| ◀H▶ ▶L▶ | 9. 3rd – 4th gear synchronizer hub    |         | 20. Output shaft                       |
| ◀H▶ ▶J▶ | 10. 3rd gear wheel                    | ◀J▶ ▶C▶ | 21. Bearing cup                        |
| ◀H▶ ▶H▶ | 11. Bearing bushing                   |         |  |

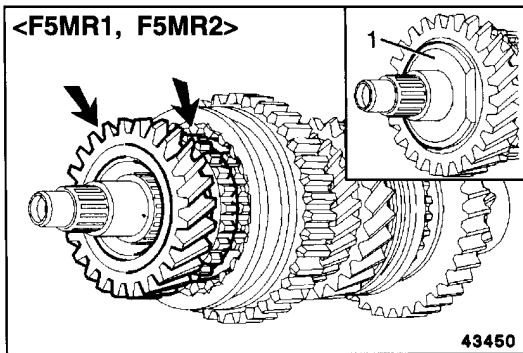

**DISASSEMBLY SERVICE POINTS**

**◀A▶ 4TH GEAR WHEEL REMOVAL**

- (1) Remove the shim 1. <F5MR1, R5MR2>
- (2) Remove the bearing and the shim. <F5MR3>
- (3) Take the gear wheel and synchronizer ring off the shaft.

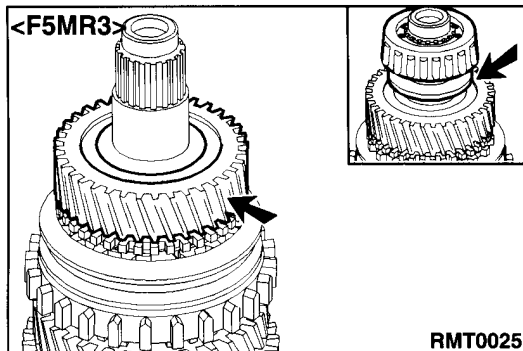

**◀B▶ 3RD – 4TH SYNCHRONIZER HUB REMOVAL**

Take the hub together with the synchronizer sleeve off the shaft.

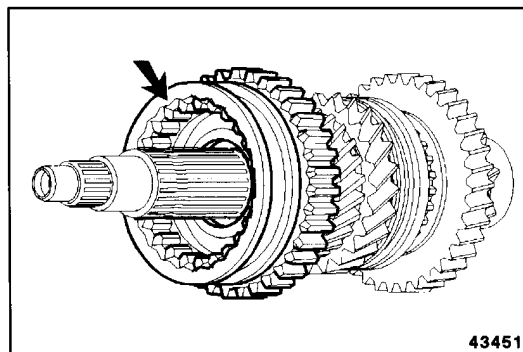

**◀C▶ 3RD GEAR WHEEL REMOVAL**

- (1) Remove the snap ring 2.
- (2) Take the blocker ring 3 together with the gear wheel and synchronizer ring off the shaft.
- (3) Remove the serrated ring 4.

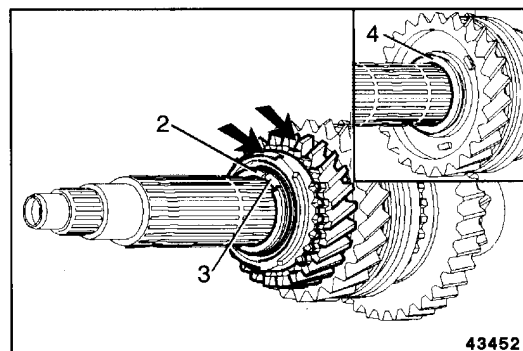

**◀D▶ 2ND GEAR WHEEL REMOVAL**

- (1) Remove the snap ring 5.
- (2) Take the gear wheel together with the synchronizer ring and the serrated ring 6 off the shaft.
- (3) Remove the serrated ring 7.

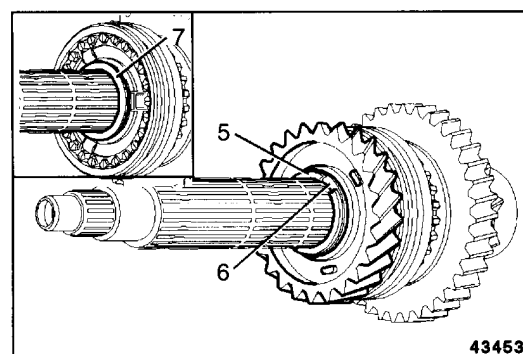

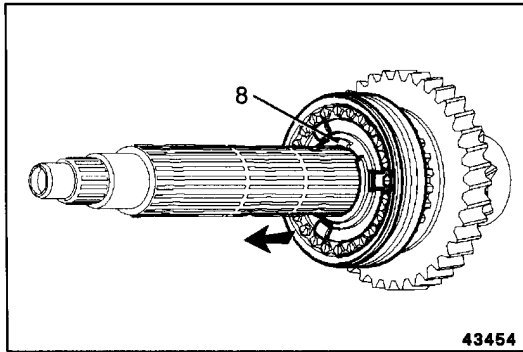

### ◀E▶ 1ST – 2ND SYNCHRONIZER HUB REMOVAL

- (1) Remove the snap ring 8.
- (2) Take the hub together with the synchronizer sleeve off the shaft.

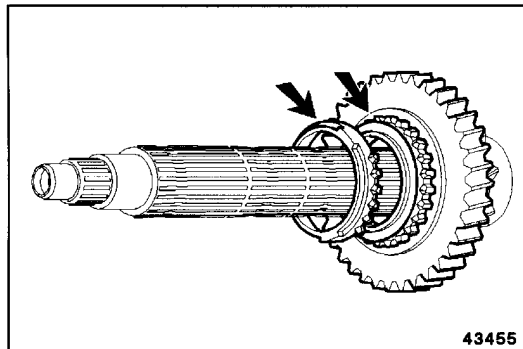

### ◀F▶ 1ST GEAR WHEEL REMOVAL

Take the gear wheel together with the synchronizer ring off the shaft.

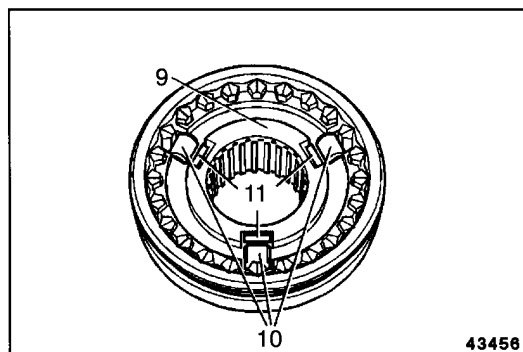

### ◀G▶ SYNCHRONIZER SPRINGS/ROLLERS REMOVAL

- (1) Press the hub 9 out of the synchronizer sleeve.
- (2) Remove the rollers 10 and springs 11.

#### NOTE

Make sure that no parts are lost.

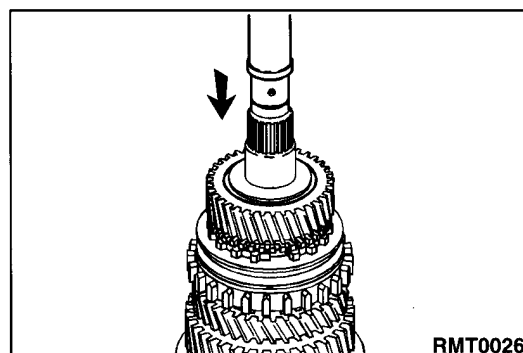

### ◀H▶ OUTPUT SHAFT FROM/GEAR WHEELS REMOVAL

- (1) Place the output shaft under a press and support the 1st gear wheel.
- (2) Press the output shaft completely out of the bearing bushes of the gear wheels.

#### NOTE

The bearing bush of the 1st gear wheel cannot be disassembled.

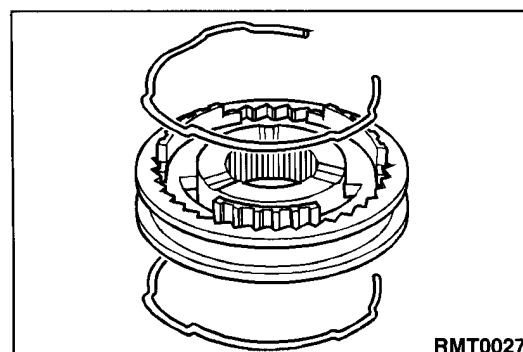

### ◀I▶ SYNCHRONIZER SPRINGS REMOVAL

- (1) Press the hub out of the synchronizer sleeve.
- (2) Remove the two springs.

#### NOTE

Make sure that none of the parts are lost.

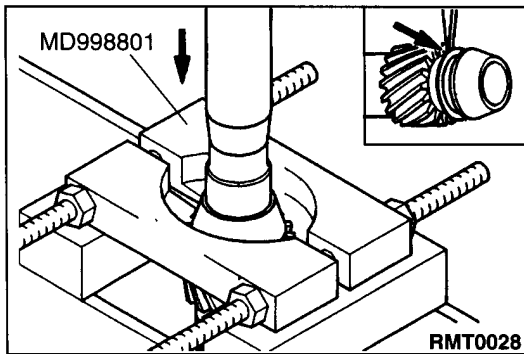

**◀J▶ BEARING CUP/OUTPUT SHAFT REMOVAL**

- (1) Place the output shaft on a soft surface.
- (2) Tap the bearing cup partway off the output shaft with a chisel.
- (3) Locate the bearing remover MD998801 behind the bearing cup.
- (4) Press the output shaft out of the bearing cup.

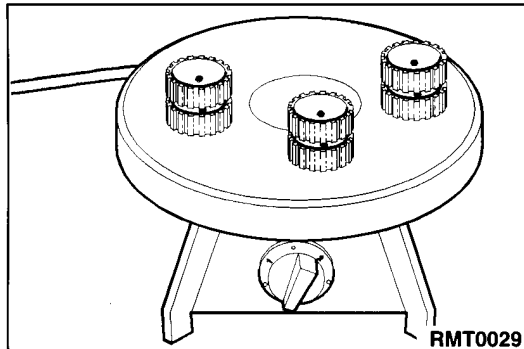

**PREPARATION BEFORE REASSEMBLY  
<F5MR3>**

**BEARING BUSHES INSTALLATION**

- (1) Place the three bearing bushes on a hot plate.
- (2) Heat the bearing bushes to 150°C maximum.

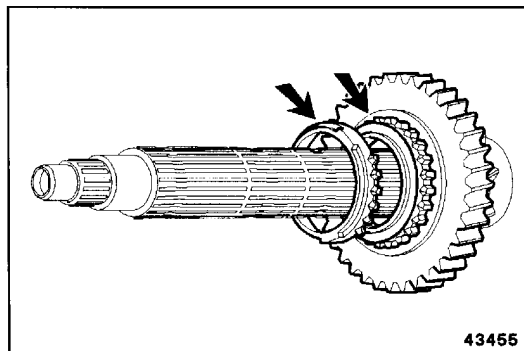

**REASSEMBLY SERVICE POINTS**

**▶A◀ 1ST GEAR WHEEL INSTALLATION**

Locate the gear wheel together with the synchronizer ring on the shaft.

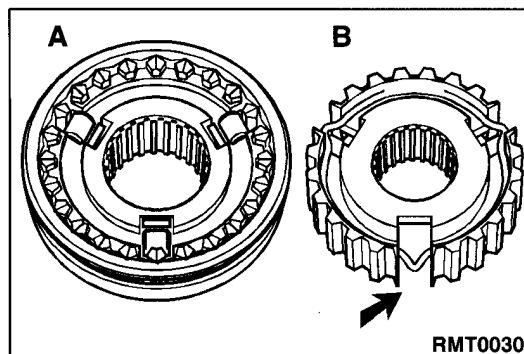

**▶B◀ SYNCHRONIZER SPRINGS INSTALLATION**

- (1) Place the hub on a workbench.
- (2) Position the two synchronizer springs so that the wider sections engage the recesses in the hub.
- (3) Locate the synchronizer sleeve on the hub.

**NOTE**

Take special note of the engaging sleeve lugs.

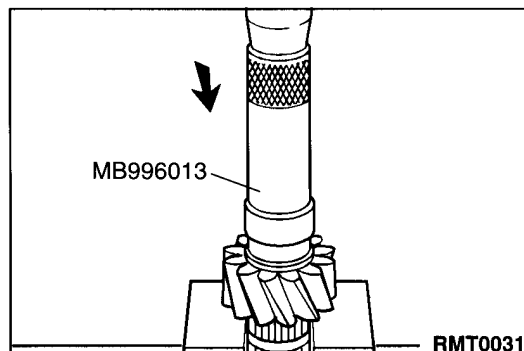

**▶C◀ OUTPUT SHAFT BEARING CUP INSTALLATION**

- (1) Place the output shaft under a press and support the 1st gear wheel.
- (2) Press the bearing cup on to the output shaft with bearing drift MB996013.



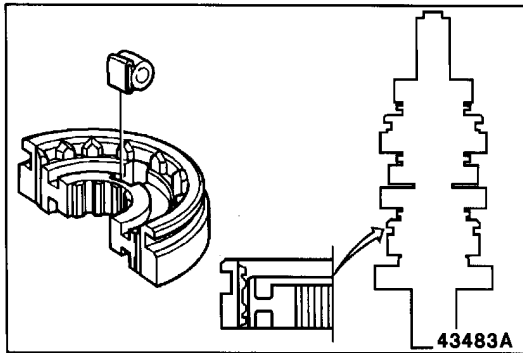

### ►D◄ 1ST – 2ND SYNCHRONIZER HUB INSTALLATION

- (1) Place the hub on a workbench.
- (2) Locate the synchronizer sleeve on the hub with the groove for the selector fork facing up; see the illustration.
- (3) Locate the three synchronizer springs together with the rollers in the hub.

#### NOTE

Always use new synchronizer springs.

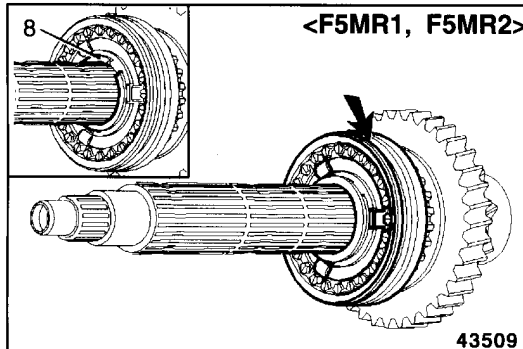

- (4) Locate the hub together with the synchronizer sleeve on the shaft.
- (5) Fit a new snap ring 8 <F5MR1, F5MR2> or synchronizer ring <F5MR3>.

#### NOTE

Make sure that the lugs of the synchronizer ring engage the recesses in the synchronizer sleeve.

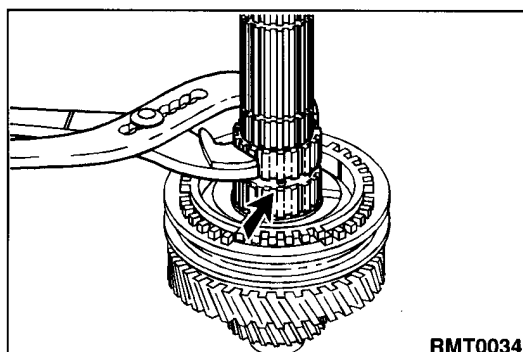
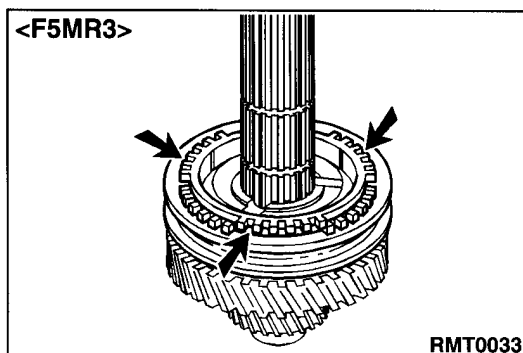

### ►E◄ 2ND GEAR WHEEL BEARING BUSH INSTALLATION

- (1) Locate the bearing bush so that the oil passages of the bearing bush and the output shaft are opposed.
- (2) Place the heated bearing bush, using a pair of gripping pliers, over the output shaft on the synchronizer hub.

#### NOTE

Allow the bearing bush to cool and then lubricate copiously with transmission fluid.

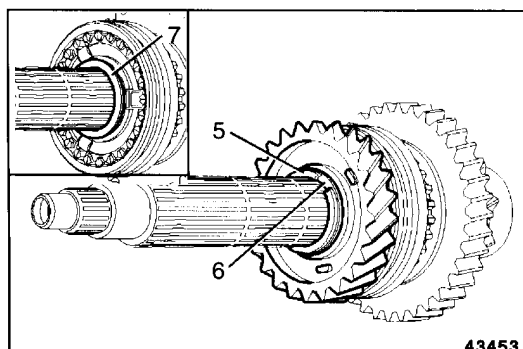

### ►F◄ 2ND GEAR WHEEL INSTALLATION

- (1) Locate the serrated ring 7 (thickness: 1.5 mm) with the bevelled edge facing towards the gear wheel.
- (2) Locate the gear wheel together with the synchronizer ring on the shaft.
- (3) Fit the serrated ring 6 (thickness: 2.5 mm) with the bevelled edge facing towards the gear wheel.
- (4) Fit a new snap ring 5.

#### NOTE

Make sure that the lugs of the synchronizer ring engage the recesses in the synchronizer sleeve.

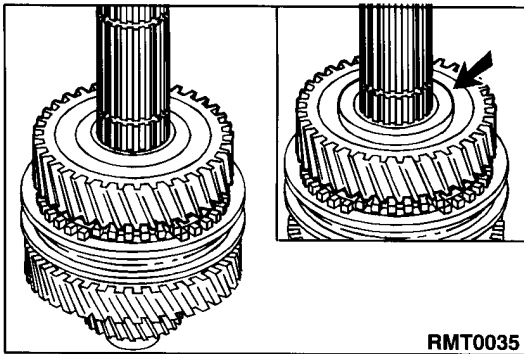

**►G◄ 2ND GEAR WHEEL INSTALLATION**

- (1) Locate the gear wheel on the bearing bush.
- (2) Fit the shim.

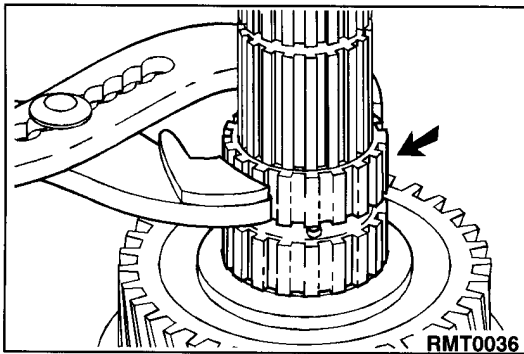

**►H◄ 3RD GEAR WHEEL BEARING BUSH INSTALLATION**

- (1) Locate the bearing bush so that the oil passages of the bearing bush and the output shaft are opposed.
- (2) Place the heated bearing bush, using a pair of gripping pliers, over the output shaft on the shim.

**NOTE**

Allow the bearing bush to cool and then lubricate copiously with transmission fluid.

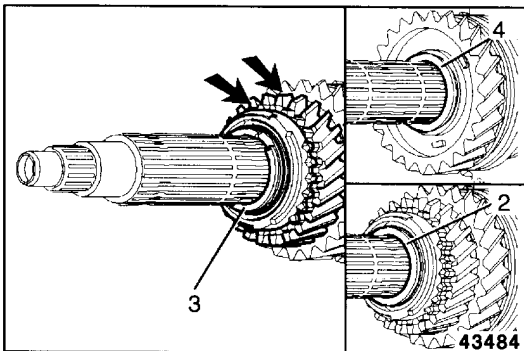

**►I◄ 3RD GEAR WHEEL INSTALLATION**

- (1) Locate the serrated ring 4 (thickness: 1.5 mm) with the bevelled edge facing towards the gear wheel.
- (2) Locate the gear wheel together with the synchronizer ring on the shaft.
- (3) Locate the serrated ring 2 (thickness: 1.5 mm) with the bevelled edge facing towards the gear wheel.
- (4) Fit a new snap ring 3.

**NOTE**

Make sure that the lugs of the synchronizer ring engage the recesses in the synchronizer sleeve.

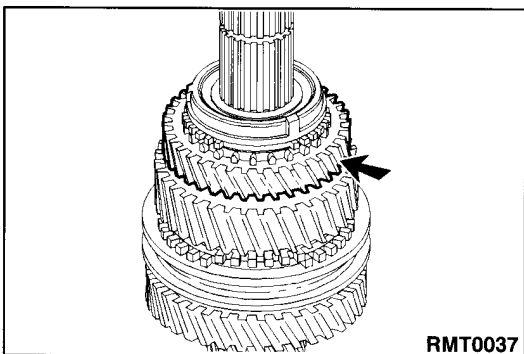

**►J◄ 3RD GEAR WHEEL INSTALLATION**

- (1) Locate the gear wheel together with the synchronizer ring on the bearing bush.

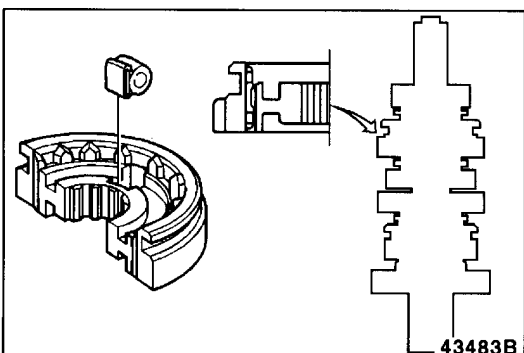

**►K◄ 3RD - 4TH SYNCHRONIZER HUB INSTALLATION**

- (1) Place the hub on a workbench.
- (2) Locate the synchronizer sleeve on the hub with the groove for the selector fork facing up; see the illustration.
- (3) Locate the three synchronizer springs together with the rollers in the hub.

**NOTE**

Always use new synchronizer springs.

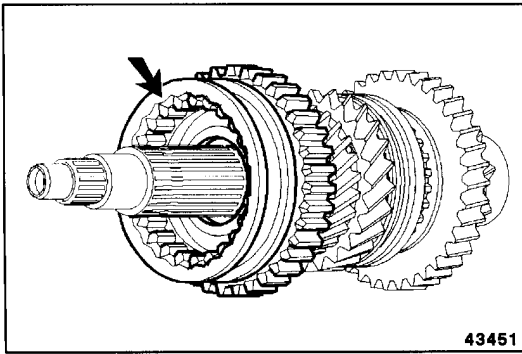

- (4) Locate the hub together with the synchronizer sleeve on the shaft with the teeth facing towards the gear wheels.

**NOTE**

Make sure that the lugs of the synchronizer ring engage the recesses in the synchronizer sleeve.

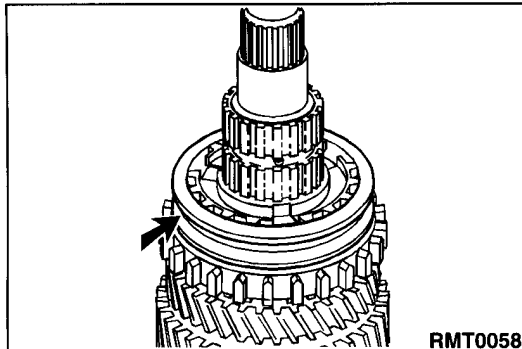

►L◄ **3RD – 4TH GEAR SYNCHRONIZER HUB INSTALLATION**

Locate the hub together with the synchronizer sleeve, with the groove for the shift fork facing up.

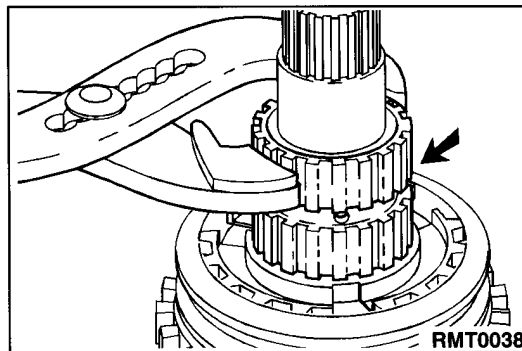

►M◄ **4TH GEAR WHEEL BEARING BUSH INSTALLATION**

- (1) Locate the bearing bush so that the oil passages of the bearing bush and the output shaft are opposed.
- (2) Place the heated bearing bush, using a pair of gripping pliers, over the output shaft on the synchronizer hub.

**NOTE**

Allow the bearing bush to cool and then lubricate copiously with transmission fluid.

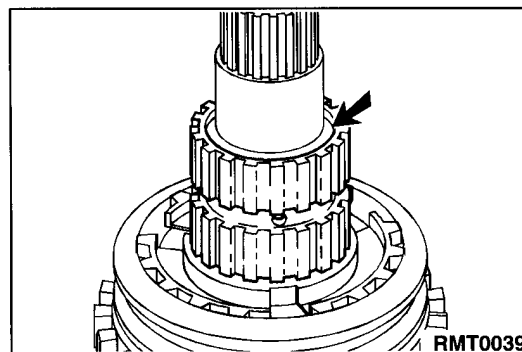

- (3) Check that the bearing bush is flush with the mating face of the output shaft and the shim. Bring the bearing bush to the same height as the mating face.

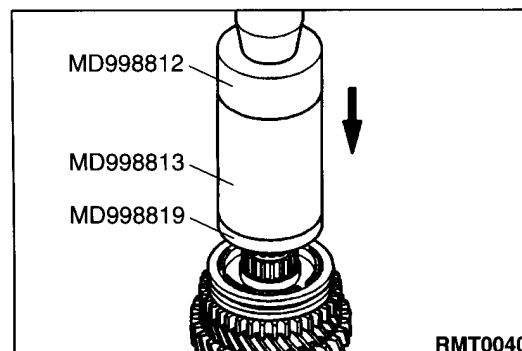

- (4) Place the output shaft under a press.
- (5) Press the bearing bush down with drift installer cap MD998812, installer – 100 MD998813, installer adapter MD998819 until the drift abuts the mating face of the shim.

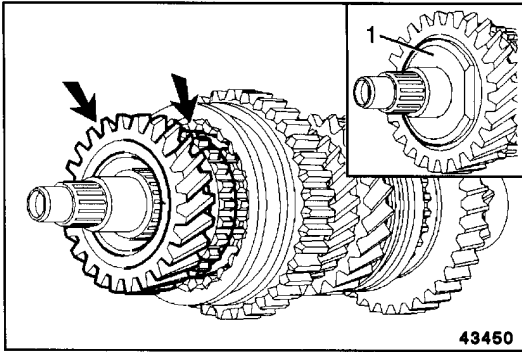

►N◄ 4TH GEAR WHEEL INSTALLATION

- (1) Locate the gear wheel together with the synchronizer ring on the shaft.
- (2) Fit the shim 1.

NOTE

Make sure that the lugs of the synchronizer ring engage the recesses in the synchronizer sleeve.

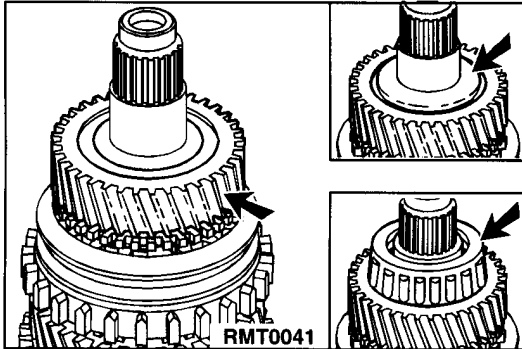

►O◄ 4TH GEAR WHEEL INSTALLATION

- (1) Locate the synchronizer ring.
- (2) Locate the gear wheel on the bearing bush.
- (3) Fit the shim.

NOTE

In the case of old bearings: fit the old shim.  
In the case of new bearings: fit a shim with a thickness of 1.6 mm.

- (4) Fit the bearing.

# 5. DIFFERENTIAL

## DISASSEMBLY AND REASSEMBLY <F5MR1, F5MR2>

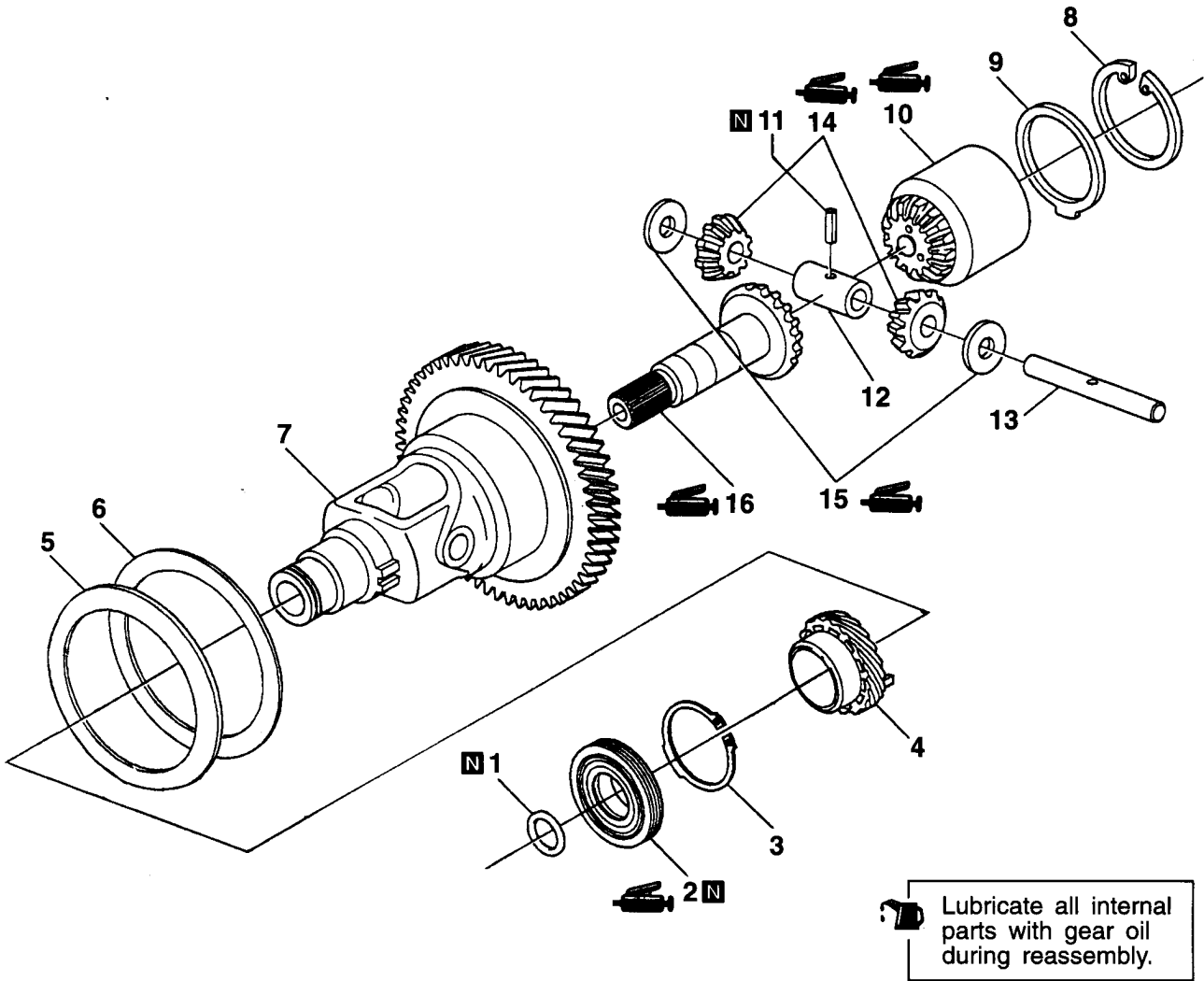

43513

### Disassembly steps

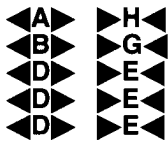

1. O-ring
2. Oil seal
3. Snap ring
4. Speedometer drive gear
5. Spring ring
6. Guard ring
7. Differential case
8. Snap ring

- |     |     |                 |
|-----|-----|-----------------|
| ◀F▶ | ▶C▶ | 9. Shim         |
|     |     | 10. Side gear   |
|     |     | 11. Spring pin  |
|     |     | 12. Bush        |
|     |     | 13. Shaft       |
| ◀G▶ | ▶B▶ | 14. Pinion gear |
|     |     | 15. Washer      |
| ◀H▶ | ▶A▶ | 16. Side gear   |

DISASSEMBLY AND REASSEMBLY <F5MR3>

 Lubricate all internal parts with gear oil during reassembly.

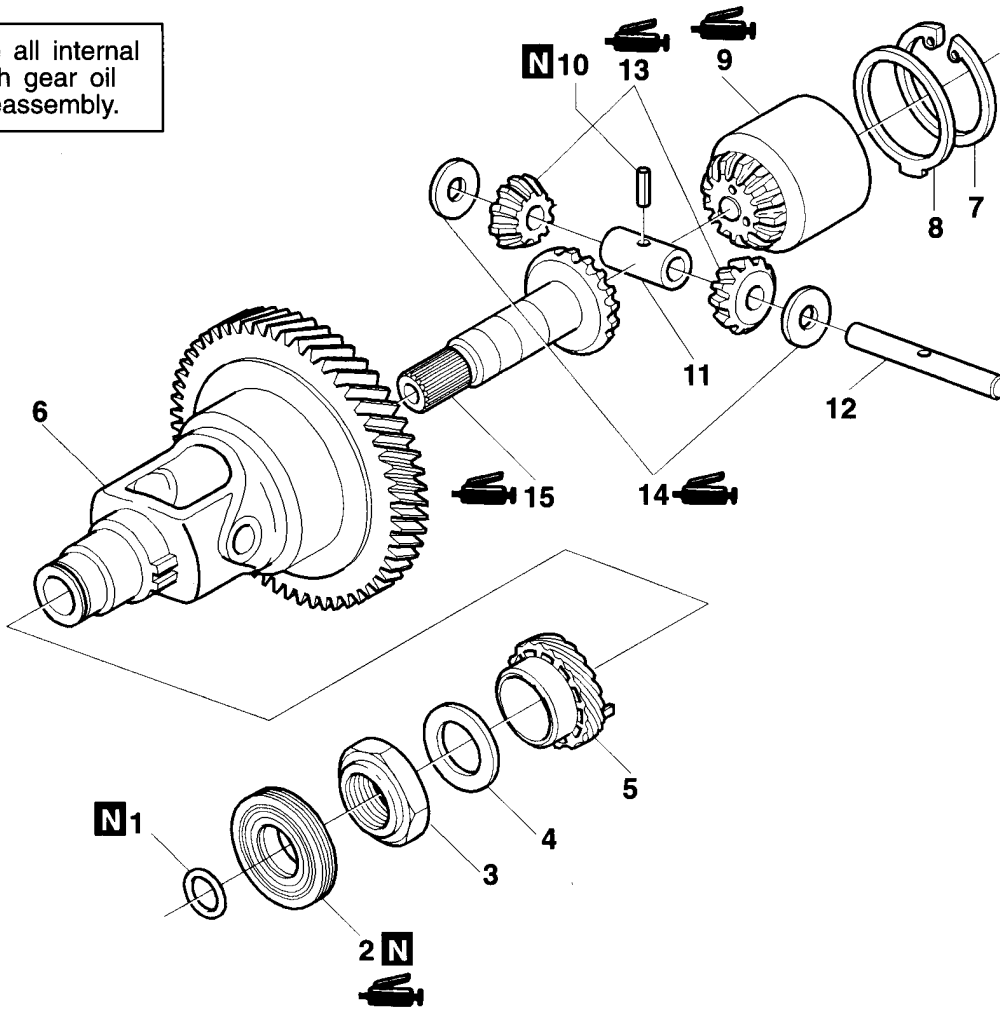

RMT0042

Disassembly steps

- |     |     |                           |     |     |                 |
|-----|-----|---------------------------|-----|-----|-----------------|
| ◀A▶ | ▶H▶ | 1. O-ring                 | ◀F▶ | ▶C▶ | 9. Side gear    |
| ◀C▶ | ▶F▶ | 2. Oil seal               |     |     | 10. Spring pin  |
|     |     | 3. Nut                    |     |     | 11. Bushing     |
|     |     | 4. Guard ring             |     |     | 12. Shaft       |
| ◀E▶ | ▶D▶ | 5. Speedometer drive gear | ◀G▶ | ▶B▶ | 13. Pinion gear |
|     |     | 6. Differential case      |     |     | 14. Washer      |
|     |     | 7. Snap ring              | ◀H▶ | ▶A▶ | 15. Side gear   |
|     |     | 8. Shim                   |     |     |                 |

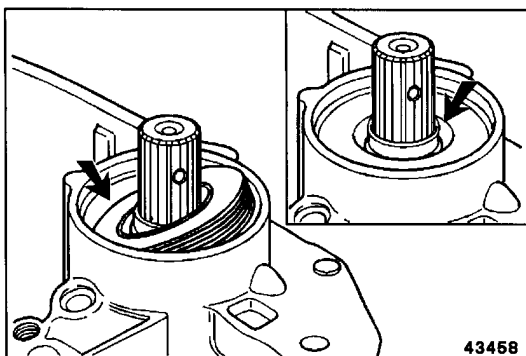

**DISASSEMBLY SERVICE POINTS**

**◀A▶ OIL SEAL REMOVAL**

- (1) Remove the O-ring.
- (2) Tap the oil seal inwards at one side and remove it at the other side.

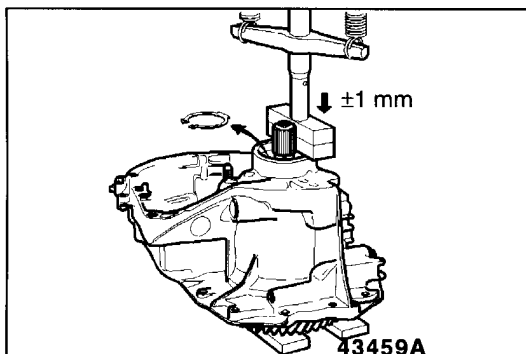

**◀B▶ SNAP RING REMOVAL**

- (1) Place the clutch housing under a press and support the differential gear assembly.
- (2) Press the clutch housing downwards (1 mm).
- (3) Make sure that the bearing abuts accurately against its seating.

**NOTE**

The open side of the bearing must be facing inwards.

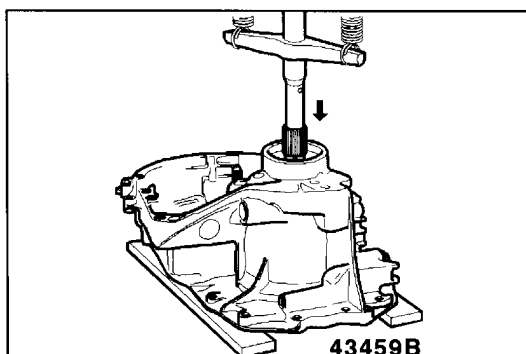

- (4) Support the clutch housing and press cut the differential assembly out.

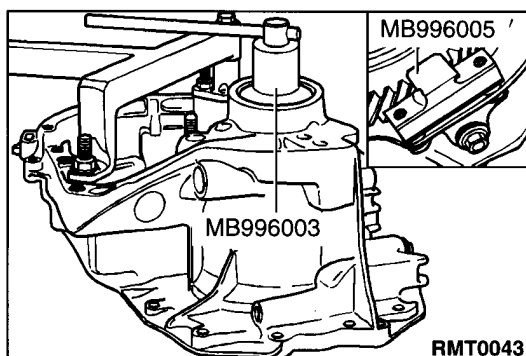

**◀C▶ DIFFERENTIAL GEAR ASSEMBLY REMOVAL**

- (1) Lock the differential gear assembly with counterhold MB996005.
- (2) Remove the nut with socket wrench MB996003.
- (3) Remove the counterhold and take out the differential gear assembly.
- (4) Remove the shim.
- (5) Take out the bearing.

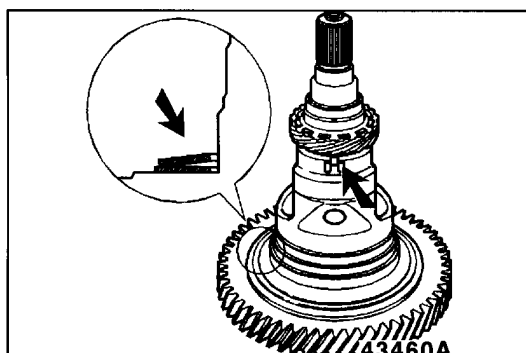

**◀D▶ SPEEDOMETER DRIVE GEAR/SPRING RING/ GUARD GEAR REMOVAL**

- (1) Take the speedometer drive gear off the differential.
- (2) Remove the spring ring.
- (3) Remove the guard ring.

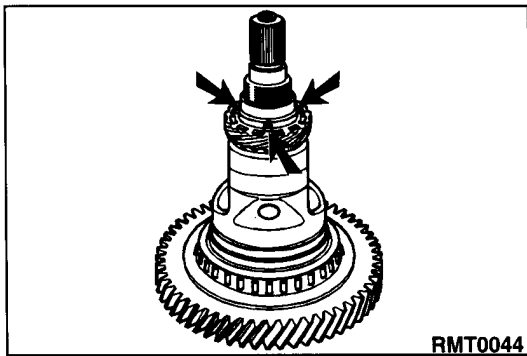

### ◀E▶ SPEEDOMETER DRIVE GEAR REMOVAL

Take the speedometer drive gear out of the differential.

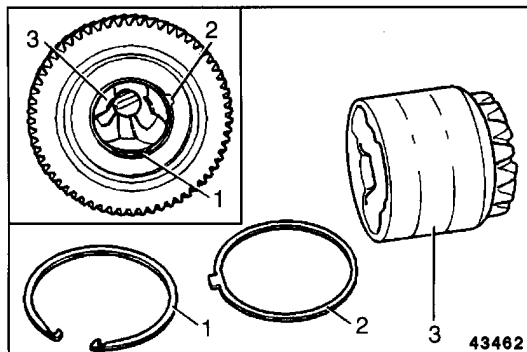

### ◀F▶ SIDE GEAR REMOVAL

- (1) Remove the snap ring 1.
- (2) Remove the shim 2.
- (3) Withdraw the side gear 3.

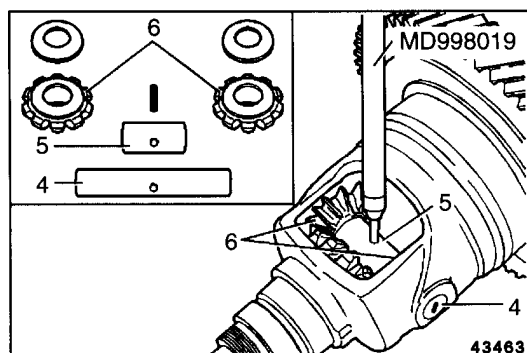

### ◀G▶ PINION GEAR REMOVAL

- (1) Remove the spring pin with spring pin extractor MD998019.
- (2) Take out the shaft 4 together with the bush 5.
- (3) Remove the pinion gears 6 together with the thrust washers.

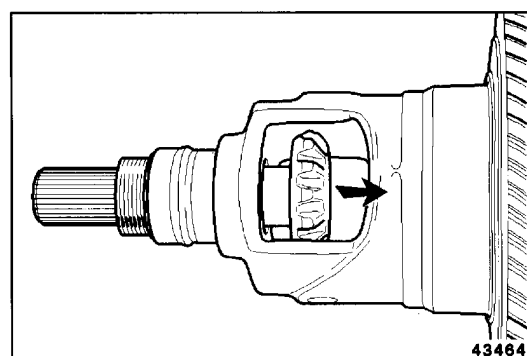

### ◀H▶ SIDE GEAR REMOVAL

Take the side gear out of the differential case.

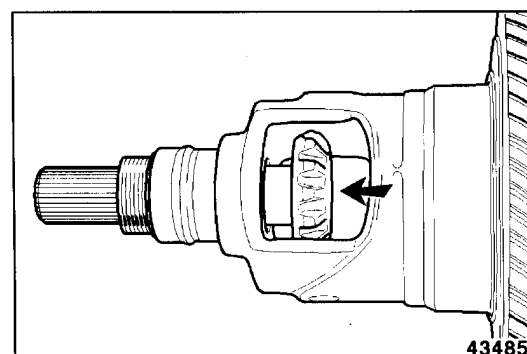

## REASSEMBLY SERVICE POINTS

### ▶A◀ SIDE GEAR INSTALLATION

- (1) Smear the side gears with grease.
- (2) Locate the side gear in the differential case.



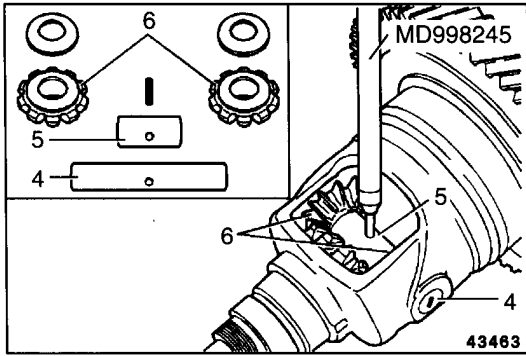

►B◄ PINION GEARS INSTALLATION

- (1) Smear the pinion gears and thrust washers with grease.
- (2) Locate the pinion gears 6 together with the thrust washers and fit the shaft 4.
- (3) Locate the bush 5 over the shaft.
- (4) Locate the pinion gears 6 together with the thrust washers and press the shaft in further.
- (5) Fit the spring pin with the slit at right-angles to the shaft and tap it in with spring pin installer MD998245.

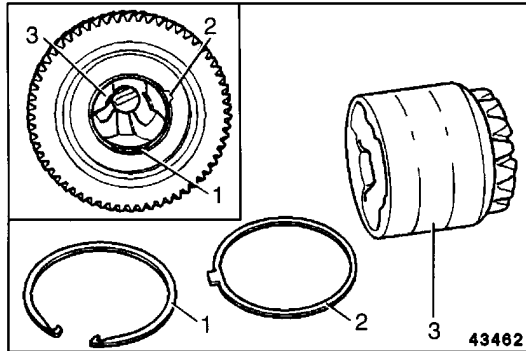

►C◄ SIDE GEAR INSTALLATION

- (1) Smear the side gears with grease.
- (2) Insert the side gear 3.
- (3) Locate the shim 2.
- (4) Fit the snap ring 1.

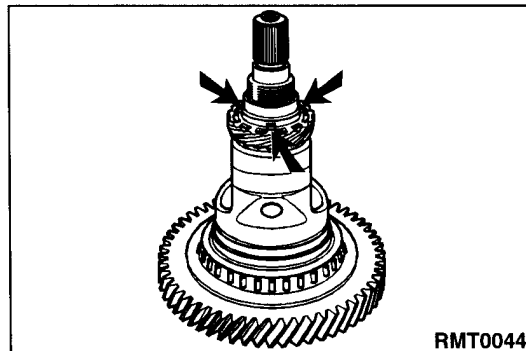

►D◄ SPEEDOMETER DRIVE GEAR INSTALLATION

- (1) Locate the speedometer drive gear with the locking lug in the recess in the differential.
- (2) Place the guard ring on the differential.
- (3) Place the spring ring on the differential.

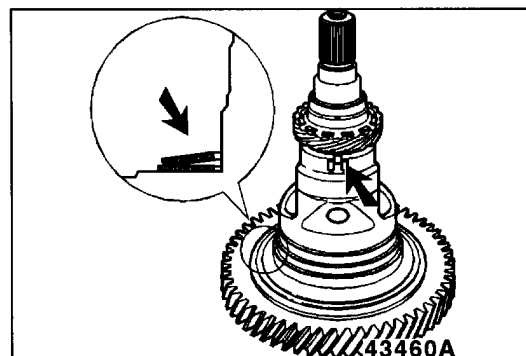

►E◄ SPEEDOMETER DRIVE GEAR/SPRING RING/GUARD GEAR INSTALLATION

- (1) Locate the speedometer drive gear with the locking lug in the recesses in the differential.
- (2) Place the guard ring on the differential.
- (3) Place the spring ring on the differential.

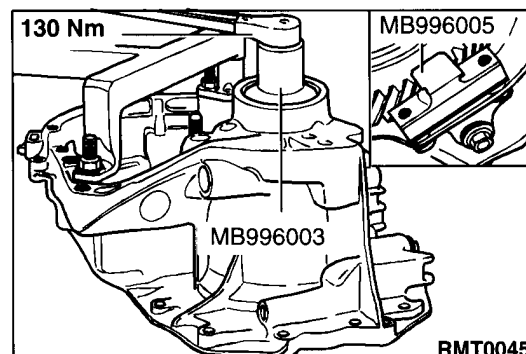

►F◄ DIFFERENTIAL GEAR ASSEMBLY INSTALLATION

- (1) Locate the differential gear assembly in the clutch housing.
- (2) Lock the differential gear assembly with counterhold MB996005.
- (3) Fit the shim.
- (4) Locate the bearing.
- (5) Smear the nut with a locking agent (Loctite 270).
- (6) Fit the nut with the opening facing towards the bearing.

- (7) Press the nut on to the threaded end with socket wrench MB996003 until it catches the thread and then tighten the nut to 18 Nm.
- (8) Remove the counterhold.
- (9) Rotate the differential a few times.
- (10) Fit counterhold MB996005.
- (11) Tighten the nut to 130 Nm.
- (12) Remove the counterhold.

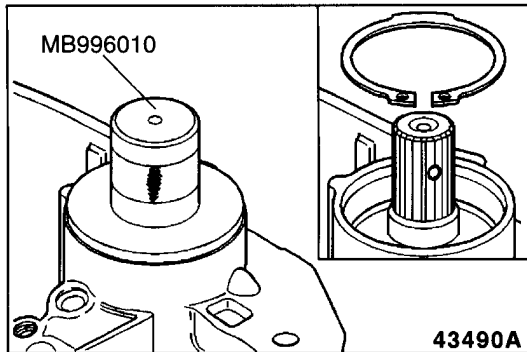

#### ►G◄ SNAP RING INSTALLATION

- (1) Locate the differential in the clutch housing.
- (2) Place the clutch housing under a press and support the differential.
- (3) Using special tool MB996010, press the housing downwards until it abuts against the stop.
- (4) Now press the housing downwards, against the spring pressure, until it is possible to fit the snap ring.
- (5) Fit the snap ring.

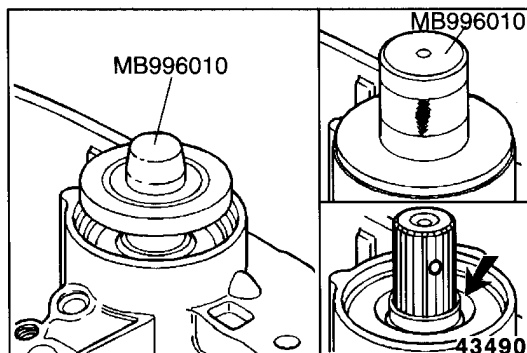

#### ►H◄ OIL SEAL INSTALLATION

- (1) Pack the lip of the new oil seal with grease.
- (2) Place the guide on the shaft and locate the oil.
- (3) Fit the oil seal with drift MB996010.
- (4) Fit a new O-ring.

## 6. CLUTCH HOUSING

### DISASSEMBLY AND REASSEMBLY <F5MR1, F5MR2>

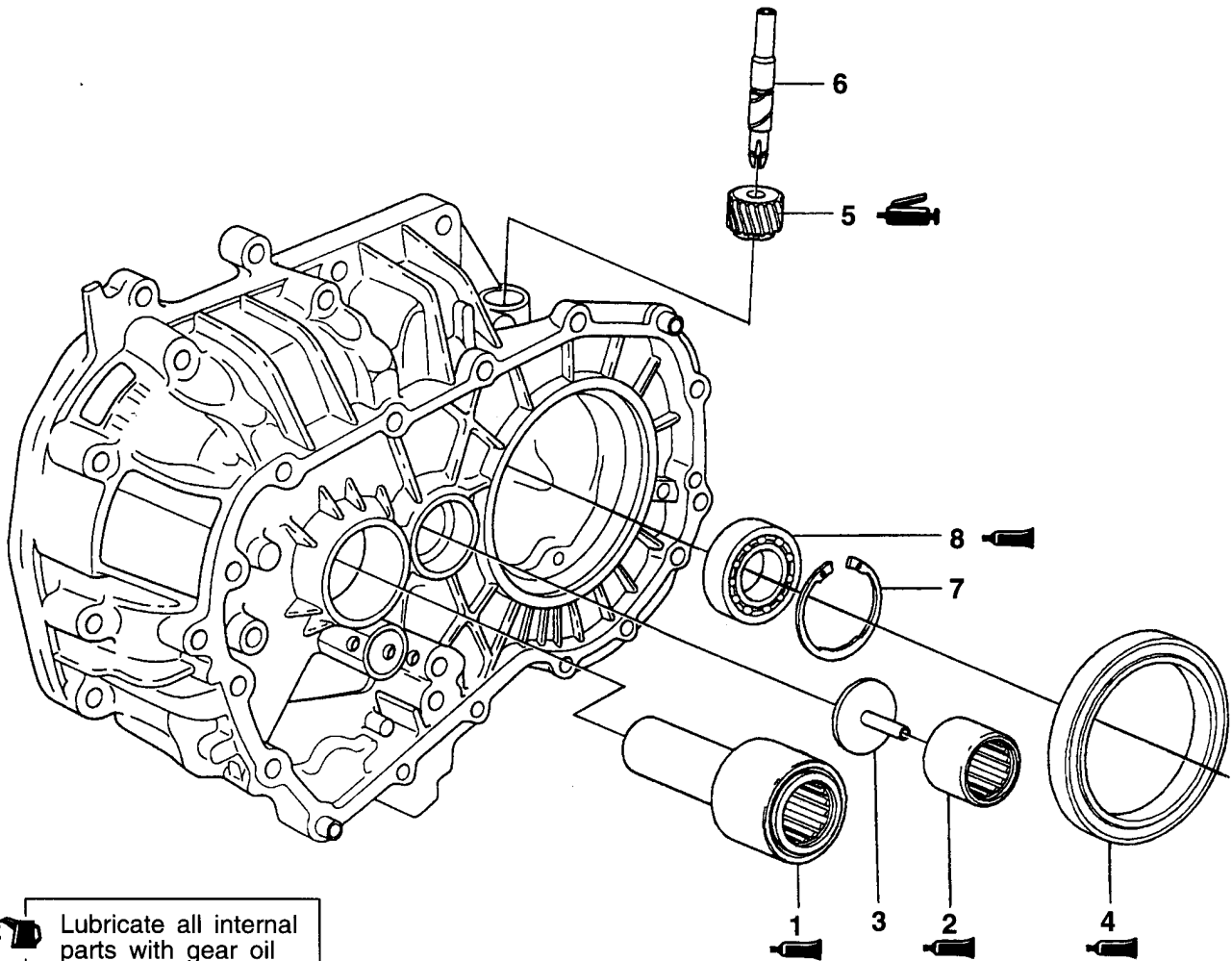

43510

#### Disassembly steps

- |     |     |                           |
|-----|-----|---------------------------|
| ◀A▶ | ▶G▶ | 1. Input shaft bearing    |
| ◀C▶ | ▶E▶ | 2. Output shaft bearing   |
|     |     | 3. Oil baffle             |
| ◀E▶ | ▶D▶ | 4. Large bearing          |
| ◀F▶ | ▶C▶ | 5. Speedometer drive gear |
|     |     | 6. Shaft                  |
|     |     | 7. Snap ring              |
| ◀G▶ | ▶A▶ | 8. Small bearing          |

DISASSEMBLY AND REASSEMBLY <F5MR3>

 Lubricate all internal parts with gear oil during reassembly.

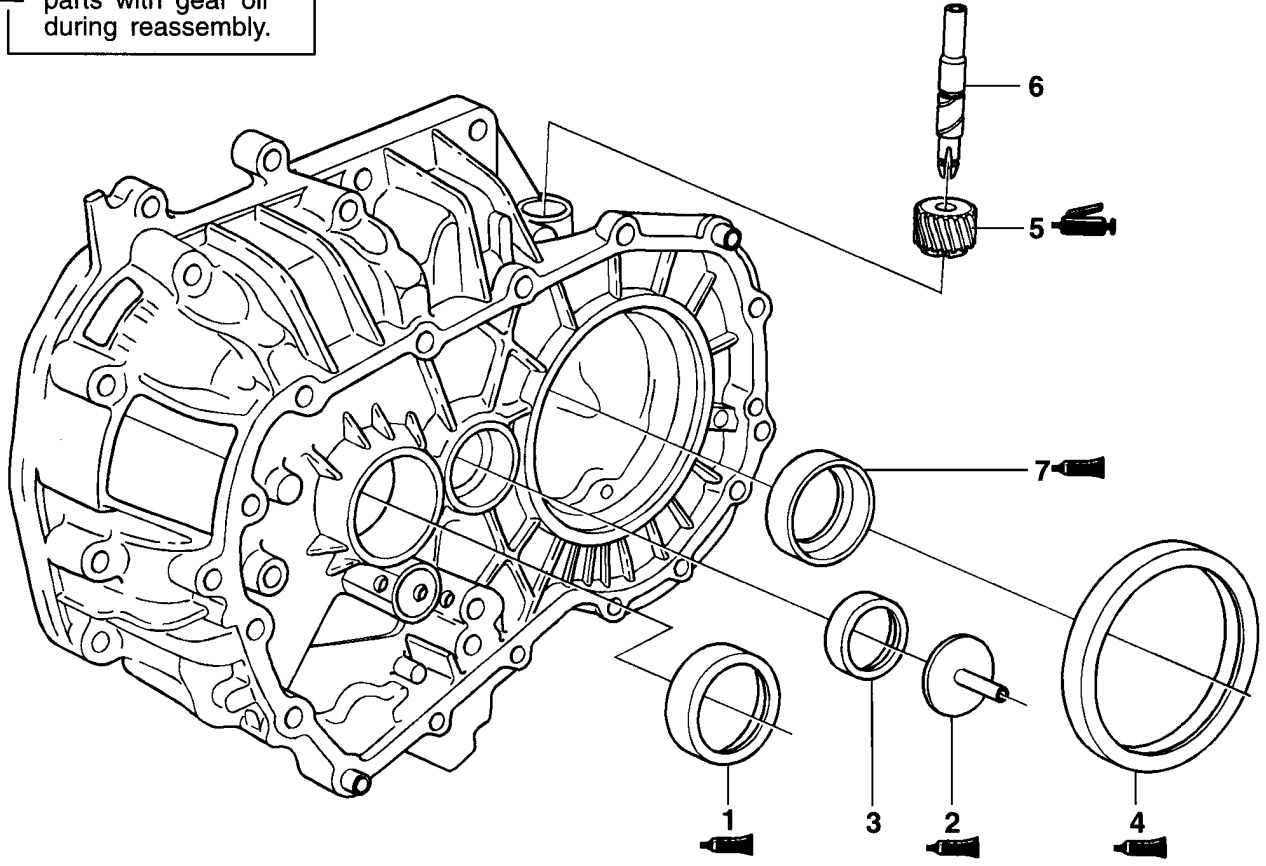

RMT0046

**Disassembly steps**

- ◀B▶ ▶H▶ 1. Input shaft bearing cup
- ◀D▶ ▶F▶ 2. Output shaft bearing
- 3. Oil baffle
- ◀C▶ ▶B▶ 4. Large bearing cup
- ◀F▶ ▶C▶ 5. Speedometer drive gear
- 6. Shaft
- ◀H▶ ▶B▶ 7. Small bearing cup

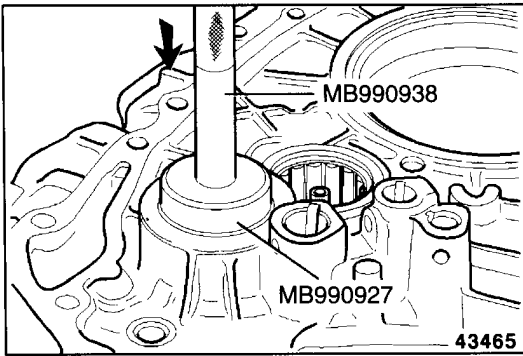

**DISASSEMBLY SERVICE POINTS**

**◀A▶ INPUT SHAFT BEARING REMOVAL**

Tap the bearing out of the housing with handle MB990938 and bearing installer set MB990927.

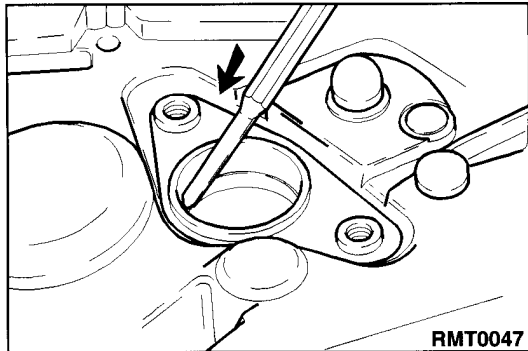

**◀B▶ INPUT SHAFT BEARING CUP REMOVAL**

Tap the bearing cup out of the housing with a drift.

**NOTE**

Take care not to damage any of the parts.

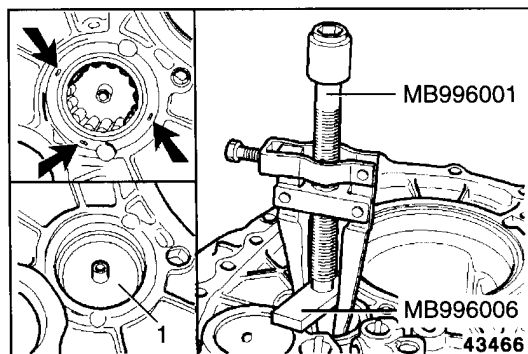

**◀C▶ OUTPUT SHAFT BEARING REMOVAL**

- (1) Tap back the upset (staked) edges of the lock washer with a punch.
- (2) Locate puller MB996001 in the bearing and position bracket MB996006 between the jaws.
- (3) Pull the bearing out of the housing.
- (4) Remove the oil baffle 1.

**NOTE**

Remove all traces of the staking with emery cloth.

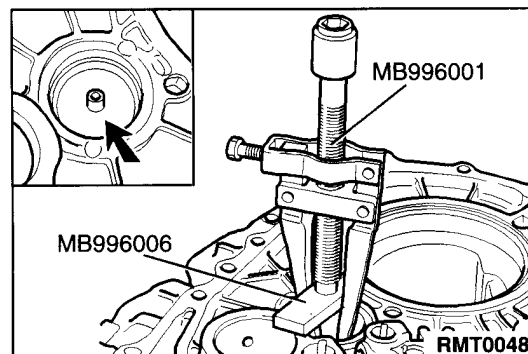

**◀D▶ OUTPUT SHAFT BEARING REMOVAL**

- (1) Locate bearing puller MB996001 in the bearing and position the bracket MB996006 between the jaws.
- (2) Pull the bearing out of the housing.
- (3) Remove the oil baffle.

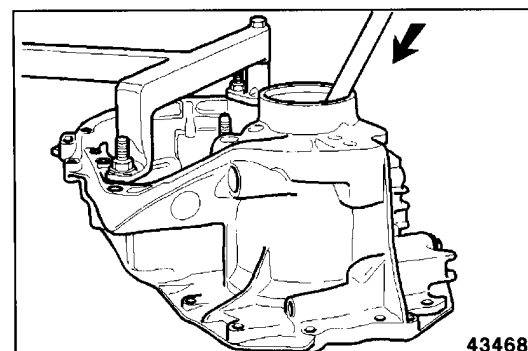

**◀E▶ LARGE BEARING REMOVAL**

Tap the bearing cup out of the housing with a long punch.

**NOTE**

Take care not to damage any parts.

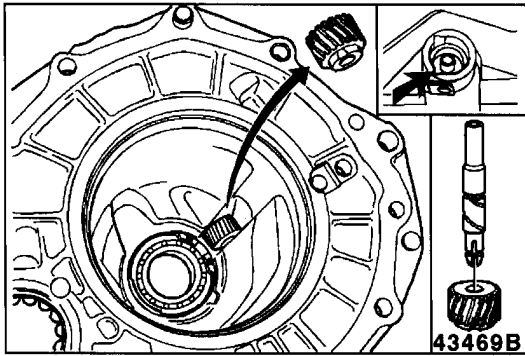

### ◀F▶ SPEEDOMETER DRIVE GEAR REMOVAL

- (1) Pull the shaft out of the speedometer drive gear with a pair of needle nose pliers.

#### NOTE

Break the shaft if it cannot be released.

- (2) Take the speedometer drive gear out of the differential housing.

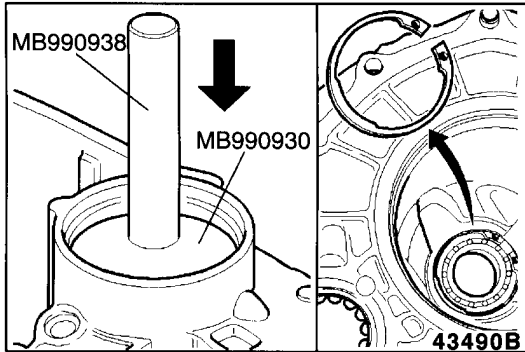

### ◀G▶ SMALL BEARING REMOVAL

- (1) Remove the snap ring with a pair of pliers.
- (2) Remove the bearing with handle MB990938 and installer MB990930.
- (3) In the case of a new clutch housing, transfer the following parts:
  - Studs
  - Fitted sleeves

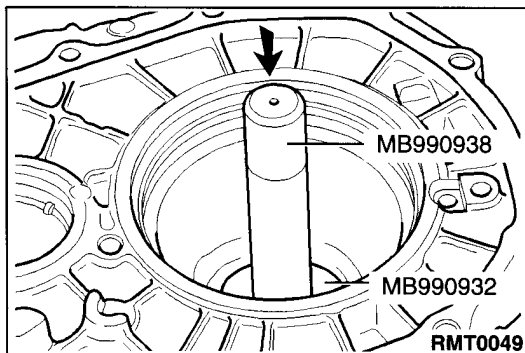

### ◀H▶ SMALL BEARING CUP REMOVAL

- (1) Remove the bearing cup with handle MB990938 and installer MB990932.
- (2) In the case of a new clutch housing, transfer the following parts:
  - threaded ends;
  - fitted dowels.

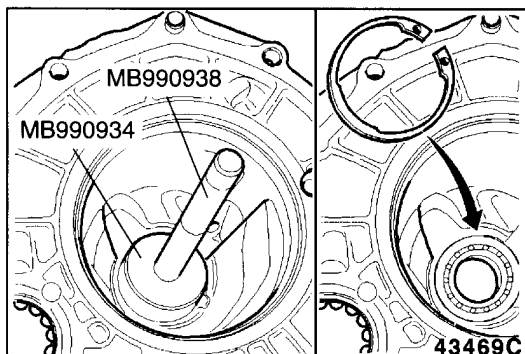

## REASSEMBLY SERVICE POINTS

### ▶A◀ SMALL BEARING INSTALLATION

- (1) Coat the mating face with the specified sealant.
- (2) Press in the bearing with handle MB990938 and installer MB990934.
- (3) Fit the snap ring with a pair of pliers and secure in the groove.

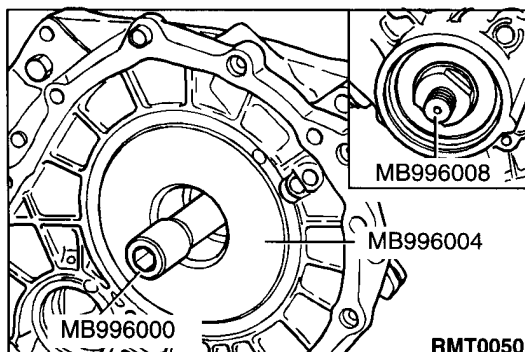

### ▶B◀ LARGE AND SMALL BEARING CUP INSTALLATION

- (1) Coat the mating faces with the specified sealant.
- (2) Press in the bearing cups with spindle MB996000 and installers MB996004 and MB996008.

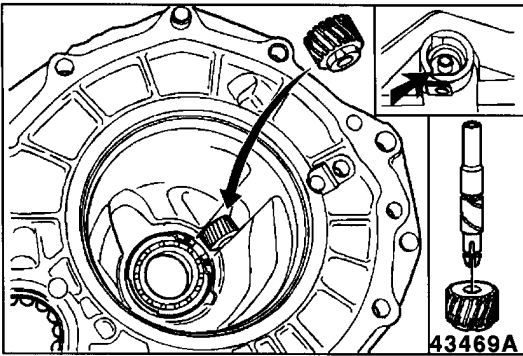

**▶C◀ SPEEDOMETER DRIVE GEAR INSTALLATION**

- (1) Introduce the shaft together with the speedometer drive gear in the clutch housing and note the position of the speedometer drive gear relative to the shaft.
- (2) Press the shaft firmly into place (snap connection).
- (3) Smear liberal amounts of grease on the gears.

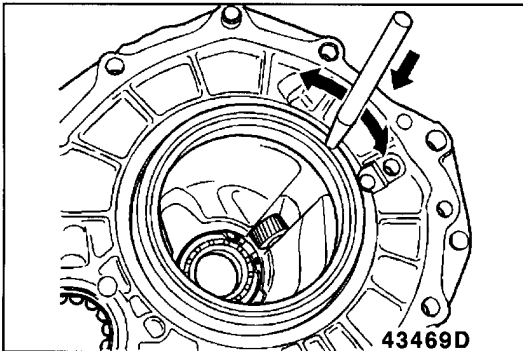

**▶D◀ LARGE BEARING INSTALLATION**

- (1) Coat the mating face with the specified sealant.
- (2) Fit the bearing by tapping it in with a plastic-hammer.
- (3) Make sure that the bearing abuts accurately against its seating.

**NOTE**

The open side of the bearing must be facing inwards.

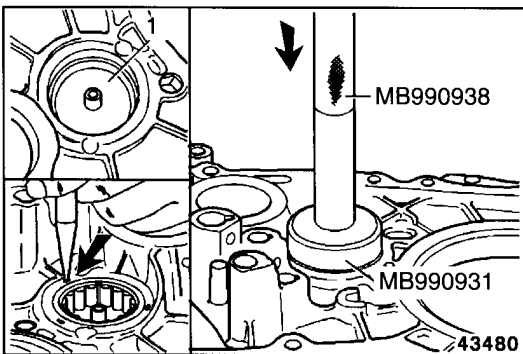

**▶E◀ OUTPUT SHAFT BEARING INSTALLATION**

- (1) Fit the oil baffle 1.
- (2) Coat the mating face with the specified sealant.
- (3) Tap in the bearing with handle MB990938 and installer MB990931.
- (4) Stake the lock washers (upset: about 1 mm) with a centre punch.

**NOTE**

The bearing must be flush with the housing.

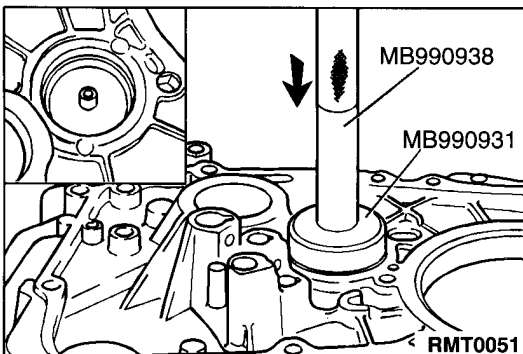

**▶F◀ OUTPUT SHAFT BEARING INSTALLATION**

- (1) Fit the oil baffle.
- (2) Coat the mating face with the specified sealant.
- (3) Tap in the bearing with handle MB990938 and installer MB990931.

**NOTE**

The bearing must be flush with the housing.

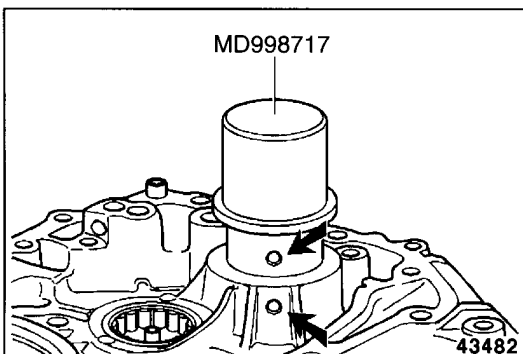

**▶G◀ INPUT SHAFT BEARING INSTALLATION**

- (1) Coat the mating face with the specified sealant.
- (2) Locate the bearing so that the oil passages of the bearing and the housing are opposed.
- (3) Press in the bearing with installer MD998717.

**NOTE**

The bearing must be flush with the housing.

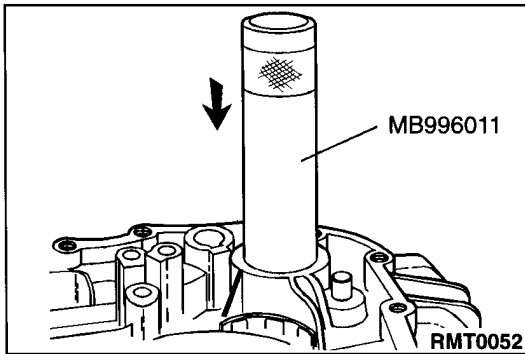
**▶H◀ INPUT SHAFT BEARING CUP INSTALLATION**

- (1) Coat the mating face with the specified sealant.
- (2) Press the bearing cup against the stop with installer MB996011.



7. CONTROL LEVER

22200790010

DISASSEMBLY AND REASSEMBLY

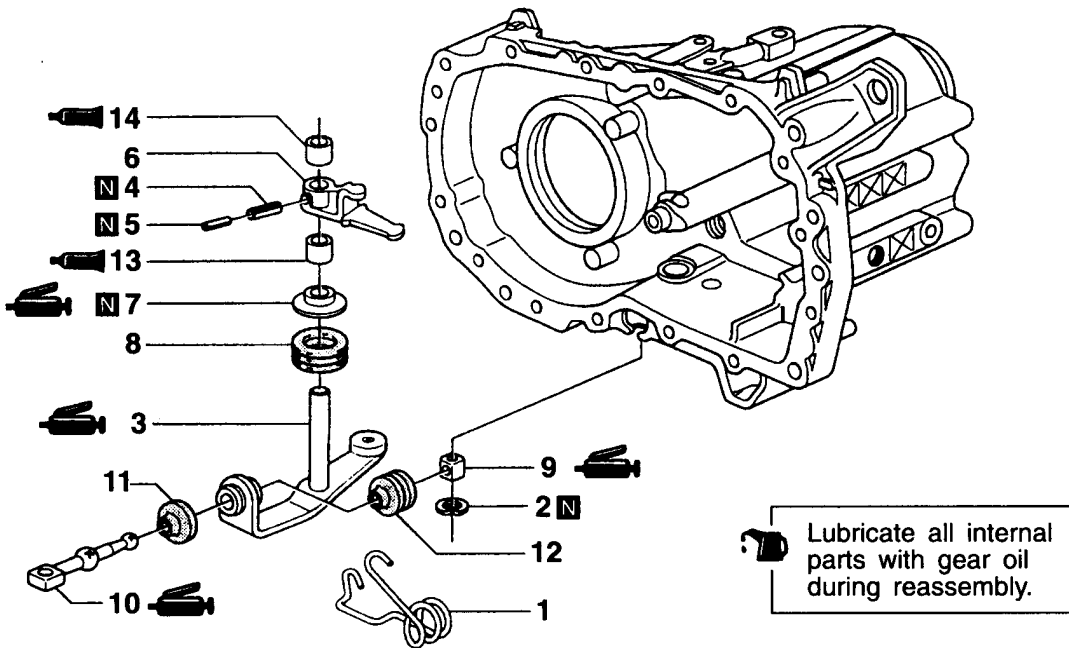

43511

Disassembly steps

- |         |                            |         |                        |
|---------|----------------------------|---------|------------------------|
|         | 1. Compression spring      |         | 8. Rubber seal         |
|         | 2. Snap ring               |         | 9. Bearing bushes      |
| ◀A▶ ▶C▶ | 3. Remote control arm      | ◀A▶ ▶C▶ | 10. Shift lever        |
|         | 4. Spring pin              |         | 11. Rubber seal        |
|         | 5. Spring pin              |         | 12. Rubber seal        |
| ◀A▶ ▶C▶ | 6. Selector dog            | ◀B▶ ▶A▶ | 13. Outer bearing bush |
| ▶B▶     | 7. Selector shaft oil seal | ◀B▶ ▶A▶ | 14. Inner bearing bush |

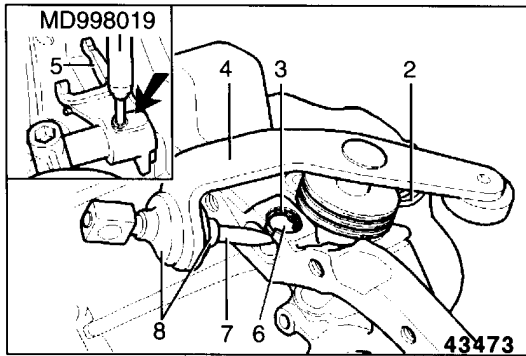
**DISASSEMBLY SERVICE POINTS****◀A▶ GEAR SHIFT MECHANISM REMOVAL**

- (1) Remove the compression spring 2 on the outside.
- (2) Remove the snap ring 3 and take out the bearing bushes.
- (3) Remove the two spring pins with spring pin extractor MD998019.
- (4) Remove the remote control arm 4.
- (5) Withdraw the shift rail assembly together with the selector dog 5.
- (6) Remove the rubber seal.
- (7) Remove the bearing bushes 6 from the shift lever 7.
- (8) Remove the rubber seal 8 from the shift lever.

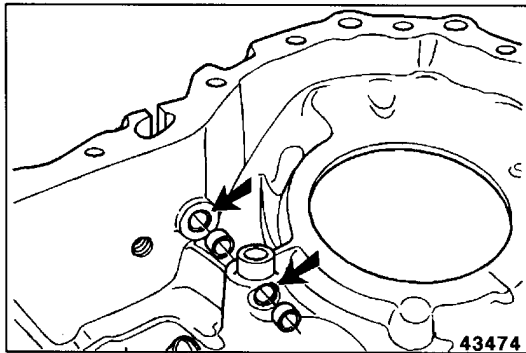
**◀B▶ BEARING BUSHES REMOVAL**

Tap out the two bearing bushes with 14 mm Hex socket.

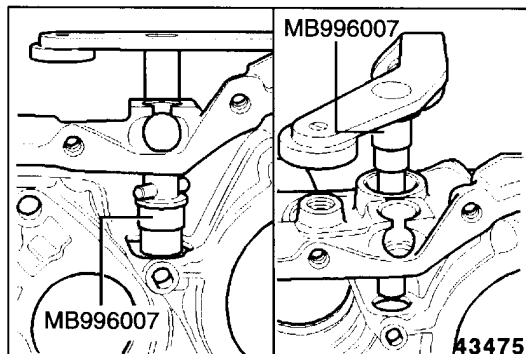
**REASSEMBLY SERVICE POINTS****▶A◀ BEARING BUSHES INSTALLATION**

- (1) Coat the mating faces of the housing with the specified sealant.
- (2) Locate the inner bearing bush and installer MB996007.
- (3) Fit the remote control arm in the housing and insert a 7.5 mm diam. punch in the spring pin hole.
- (4) Tap in the bearing bush until it abuts against its seating.
- (5) Remove the punch, remote control arm and drift MB996007.
- (6) Locate the outer bearing bush and installer MB996007.
- (7) Fit the remote control arm in the housing.
- (8) Tap in the bearing bush until it abuts against its seating.
- (9) Remove the remote control arm and installer MB996007.

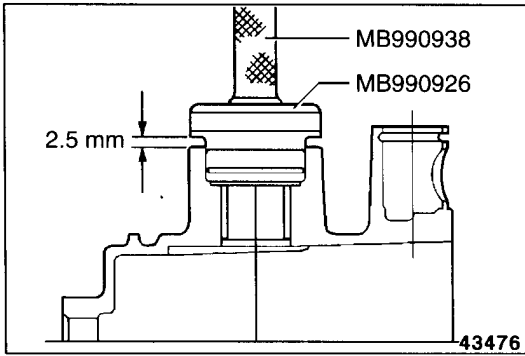

**▶B◀ SELECTOR SHAFT OIL SEAL INSTALLATION**

- (1) Pack the lip of the oil seal with grease.
- (2) Fit the new oil seal with handle MB990938 and installer MB990926 so it is located about 2.5 mm ahead of the mating face.

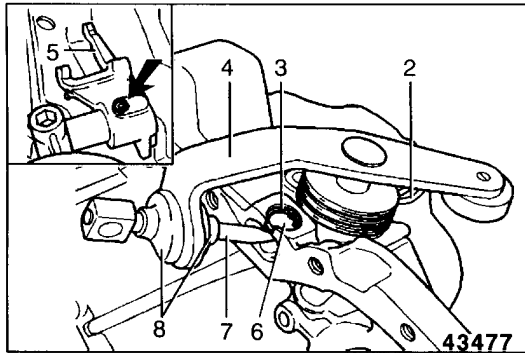

**▶C◀ GEAR SHIFT MECHANISM INSTALLATION**

- (1) Coat the shift lever (ball and socket joints) and shift rail assembly shaft with grease.
- (2) Fit the rubber seal 8 on the shift lever.
- (3) Fit the rubber seal on the shift rail assembly.
- (4) Locate the selector dog 5 and insert the remote control arm 4 in the transmission case.
- (5) Fit the two spring pins opposite each other at 180° and at right-angles to the shaft.
- (6) Locate the two bearing bushes 6 and fit the shift lever 7.
- (7) Fit the snap ring 3.
- (8) Fit the rubber seal over the oil seal.
- (9) Check for correct operation.
- (10) Fit the compression spring 2 on the outside.

## 8. INPUT SHAFT <F5MR3>

### DISASSEMBLY AND REASSEMBLY



Lubricate all internal parts with gear oil during reassembly.

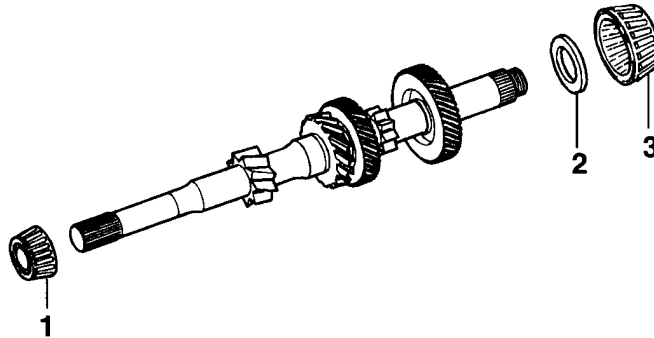

RMT0053

#### Disassembly steps

- ◀A▶ ▶B▶ 1. Bearing  
 ▶B▶ ▶A▶ 2. Shim  
 ▶B▶ ▶A▶ 3. Bearing

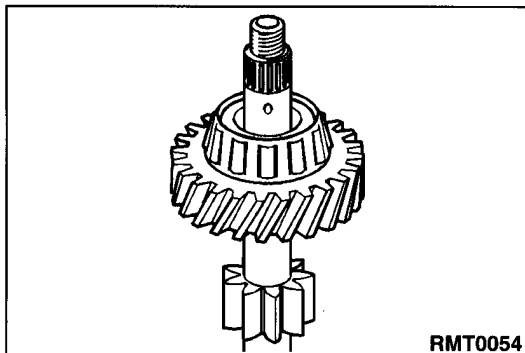

#### DISASSEMBLY SERVICE POINTS

##### ◀A▶ INPUT SHAFT BEARINGS/TRANSMISSION CASE END REMOVAL

Remove the bearing and the shim.

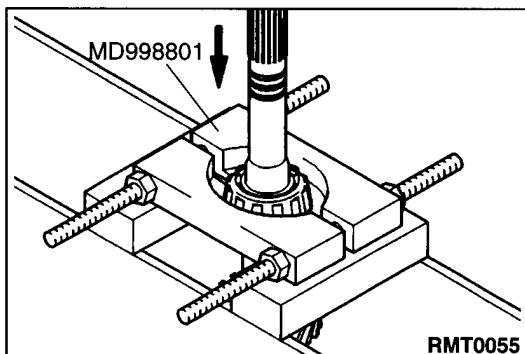

##### ▶B▶ INPUT SHAFT BEARING/CLUTCH HOUSING END REMOVAL

- (1) Place the input shaft on a soft surface.
- (2) Tap the bearing partway off the input shaft with a chisel.
- (3) Locate the bearing remover MD998801 behind the bearing.
- (4) Press the bearing of the input shaft.

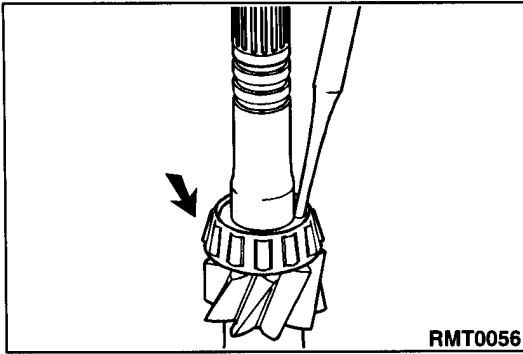
**REASSEMBLY SERVICE POINTS****▶A◀ INPUT SHAFT BEARING/CLUTCH HOUSING END INSTALLATION**

- (1) Locate the bearing on the input shaft.
- (2) Tap the bearing with a drift until it abuts against the stop on the input shaft.

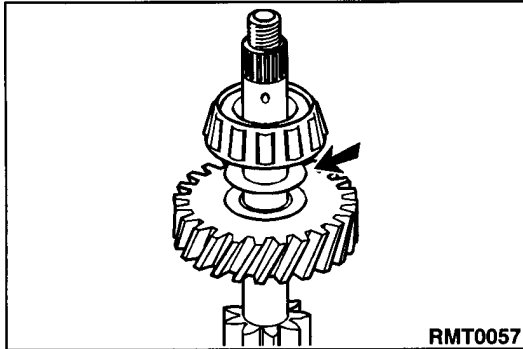
**▶B◀ INPUT SHAFT BEARING/TRANSMISSION CASE END INSTALLATION**

- (1) Fit the shim.

**NOTE**

In the case of old bearings: Fit the old shim.

In the case of new bearings: fit a shim with a thickness of 1.6 mm.

- (2) Fit the bearing.